

Last saved on 09/23/2019 3:00 PM

**TUESDAY, SEPTEMBER 24, 2019**  
**CITY COUNCIL AGENDA**  
**6:00 PM**

- I. Call to Order.
- II. Pledge of Allegiance/Invocation (Councilman Byrd).
- III. Minute Approval.
- IV. Special Presentation.

V. **Ordinances – Final Reading:**

**POLICE**

- a. [An ordinance amending Chattanooga City Code, Part II, Chapter 24, Section 24-49 relating to use of hand-held mobile telephone or personal digital assistant prohibited while driving; Chapter 24, Section 24-50-Prohibited Use of Hand-Held Mobile Telephone in Marked School Zone; and Chapter 24, Section 24-51-Prohibited Use of Mobile Telephone with Hands-Free Device by Persons under 18. \(Sponsored by Councilman Smith and Councilman Ledford\)](#)

VI. **Ordinances – First Reading: (None)**

VII. **Resolutions:**

**FINANCE**

- a. [A resolution authorizing the issuance and sale of an amount not to exceed \\$31,500,000 principal amount of the City of Chattanooga, Tennessee, General Obligation Bonds, Series 2019A.](#)
- b. [A resolution authorizing the issuance and sale of an amount not to exceed \\$24 million principal amount of the City of Chattanooga, Tennessee, General Obligation Refunding Bonds, Series 2019B.](#)

**INFORMATION TECHNOLOGY**

- c. [A resolution authorizing the Chief Information Officer to enter into a blanket agreement with CentralSquare Technologies \(d/b/a FDM Software, Ltd.\) for annual support and maintenance of RMS, including training, permitting, and inspection modules for CFD beginning August 8, 2019 and ending August 7, 2020, with annual spent limit of \\$80,000.00, for two optional annual renewals over the life of the agreement, for an amount not to exceed \\$240,000.00.](#)

**PUBLIC WORKS AND TRANSPORTATION**

**Public Works**

- d. [A resolution authorizing the Administrator for the Department of Public Works to execute a contract with the U.S. Army Corps of Engineers for Phase IV of the Chattanooga Flood Preparedness Program for an amount of \\$570,206.00, and authorizing the City's 50% match in the amount of \\$285,103.00. \(Revised\) \(Deferred from 9/17/2019\)](#)

**YOUTH AND FAMILY DEVELOPMENT**

- e. [A resolution authorizing the Administrator for the Youth and Family Development to purchase early learning curriculum from Teaching Strategies to be used in the Seats for Success Initiative and to align the City childcare program and curriculum with Head Start and pre-K curriculum, in the amount of \\$149,059.54.](#)
- f. [A resolution authorizing the Administrator for the Department of Youth and Family Development to provide services to one-hundred fifty \(150\) children through collaboration between Early Head Start – Child Care Partnership and Newton Child Development Center, Maurice Kirby Day Care Center, Chambliss Center for Children, First Step Christian Daycare, Inc., Childcare Network – Redland, and Signal Center, in the amount of \\$1,520,206.00 and as outlined in the attached.](#)

VIII. Purchases.

IX. Other Business.

- a. **Approval of certification for new grocery stores wishing to sell wine:**

**Aldi, Inc. (Tennessee) d/b/a Aldi #90, 2020 Gunbarrel Road (District 4)**

**Ria Group, Inc. d/b/a Ria's Mart, 203 E. Main Street (District 8)**

X. Committee Reports.

XI. Recognition of Persons Wishing to Address the Council on Non-Agenda Matters.

XII. Adjournment.

**TUESDAY, OCTOBER 1, 2019**  
**CITY COUNCIL AGENDA**  
**4:00 PM**

1. Call to Order.
2. Pledge of Allegiance/Invocation (Councilwoman Coonrod).
3. Minute Approval.
4. Special Presentation.
5. **Ordinances - Final Reading: (None)**
6. **Ordinances – First Reading: (None)**
7. **Resolutions:**

**ECONOMIC AND COMMUNITY DEVELOPMENT**

- a. [A resolution authorizing the Administrator for the Department of Economic and Community Development to award HOME Program funds to Chattanooga Neighborhood Enterprise, Inc. \(CNE\) for the development of twenty-four \(24\) newly constructed rental units at 2105 Bailey Avenue which five \(5\) units will be reserved as affordable for low to moderate income households, in the amount of \\$200,000.00.](#)

**FINANCE**

- b. [A resolution authorizing the City Treasurer to renew the contract with SunTrust Bank for commercial and general banking services, including purchasing cards and safekeeping and custodial accounts, and for the first of two \(2\) optional one \(1\) year renewals.](#)
- c. [A resolution authorizing the City Treasurer to renew the contract with First Tennessee Bank for commercial and general banking services, including lockbox services, payroll cards, safekeeping, and custodial accounts, and for the collection of sewer payments, property taxes, and water quality fees at branch locations, for the first of two \(2\) optional one \(1\) year renewals.](#)

**INFORMATION TECHNOLOGY**

- d. [A resolution to amend Resolution No. 29865 for the purpose of maintaining the Coplink software platform and complementary data integration services with Forensic Logic to be active from January 1, 2019 through December 31, 2019, for an increase in the annual contract spend limit from \\$39,307.00 to \\$50,000.00.](#)

**PUBLIC WORKS AND TRANSPORTATION**

**Public Works**

- e. A resolution authorizing the award of Contract No. Y-15-008-202 to Complete Demolition Services, LLC of Carrollton, GA, Avondale Youth and Family Development Center Building Abatement and Demolition, in the amount of \$103,247.55, plus a contingency amount of \$10,000.00, for a total amount of \$113,247.55. (District 8)
  
  - f. A resolution authorizing the award of Contract No. Y-19-010-201 to JDH Company, Inc. of Chattanooga, TN, Replacement Roofing System for Glenwood YFD Center, in the amount of \$150,445.00, plus a contingency amount of \$15,000.00, for a total amount of \$165,445.00. (District 9)
  
  - g. A resolution to amend Resolution No. 29935 to authorize the Administrator for the Department of Public Works to renew Contract No. S-16-011 on-call landscape architect design services for year three (3) of three (3) with (1) ASA Engineering & Consulting, Inc.; (2) Barge Design Solutions; (3) Craig Design Group; (4) Stantec; and (5) W.M. Whitaker & Associates, for one (1) year blanket contracts with five (5) professional firms for use by all departments, for an estimated total annual amount of \$500,000.00.
- 
- 8. Purchases.
  
  - 9. Other Business.
  
  - 10. Committee Reports.
  
  - 11. Recognition of Persons Wishing to Address the Council on Non-Agenda Matters.
  
  - 12. Adjournment.

**Emergency Purchase 09-24-19**

DEPARTMENT REQUISITION NO.	ITEM DESCRIPTION	BIDS REQUESTED	BIDS RETURNED	LOWEST/BEST BIDDER	COST	FUND NAME	NOTES
PO 555212 Public Works (Fire Dept)	Emergency Purchase - One (1) Waterous Single Stage Fire Pump for Fire Truck (Fire Department) - Public Works Department, Fleet Division	-	-	Waterous Company 125 Hardman Avenue S South St. Paul, MN 55075	Total Purchase \$23,714.00	General Fund	Emergency Purchase - One (1) Waterous Single Stage Fire Pump for Fire Truck (Fire Department) - Public Works Department, Fleet Division. This purchase of the frontline fire apparatus was necessary to not interrupt critical Fire Department emergency service delivery.



# City of Chattanooga

Mayor Andy Berke

**September 17, 2019**

**Mr. Justin Holland  
Administrator, Public Works Department  
Fleet Management Division  
1250 Market Street, Suite 2100  
Chattanooga, TN 37402**

**Subject: R189257 / PO No. 555212– Waterous Single Stage Fire Pump – Fleet  
Management Division – Public Works Department – K21001**

**Dear Mr. Holland:**

**It is necessary to initiate an emergency purchase for the purchase of one (1) Waterous Single Stage Fire Pump for Fire Truck No. F-058 for the Fire Department. Council approval is recommended due to this is a frontline piece of fire apparatus that needs prompt attention so as not to interrupt critical emergency service delivery. The proposed purchase is a one-time purchase to the Waterous Company. The purchase order, quote and the requisition is attached for your review.**

**In my opinion, this emergency purchase is justified and the City's best interest was served by this decision**

**Respectfully yours,**

**Emergency service provided by Waterous Company for Fleet Management/Chattanooga Fire Department is approved and should be entered in the minutes of the City Council as stipulated by Ordinance 5608, Section 3.**

A handwritten signature in blue ink that reads "Bonnie Woodward".

**Bonnie Woodward  
Director of Purchasing**

\_\_\_\_\_  
**Justin Holland  
Administrator of Public Works**

# Purchase Order STANDARD



**City of Chattanooga**  
101 East 11th Street, Suite G13  
Chattanooga, TN 37402

<b>V E N D O R</b>	Vendor Number: Vendor Alternate ID: 1132355  Waterous Company 125 Hardman Avenue S South St Paul, MN 55075
--	---

PO Date: 19-AUG-19 Buyer: Mark McKeel FOB: DESTINATION Terms: Immediate	Purchase Order Number <b>555212</b>  INVOICES: Direct invoices in DUPLICATE to the Invoice address shown below.
--	--

<b>S H I P T O</b>	Amnicola Garage, Bldg 2 3102 Elmendorf Circle Chattanooga  TN  37406
--	--

<b>I N V O I C E</b>	Accounts Payable Division City of Chattanooga 101 East 11th Street, Suite 101 Chattanooga, TN 37402
--	--

<b>Requestor</b>	<b>Requisition Number</b>	<b>Bid Number</b>
Rachel Haines	189257	

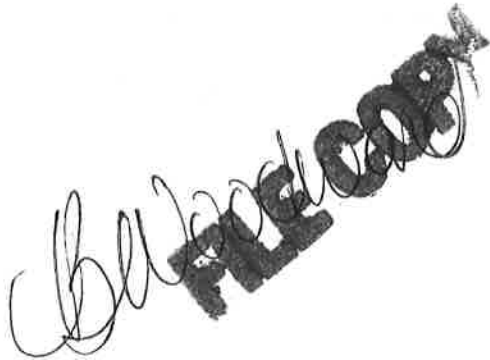
Line Nbr	Item ID - Item Description	Quantity	Unit	Unit Price	Total
***** THIS IS AN ORDER ***** ***** PLEASE DELIVER AS REQUESTED *****					
Requisition No.: 189257 Ordering Dept.: Fleet Management Division, Public Works Buyer: Mark McKeel Phone No.: 423-643-7236					
Items being purchased: S100C20C Single Stage Fire Pump					
Items being ordered from quote number 00031202 dated 08/07/19. Emergency Purchase per the Fire Department					
Please Ship to: City of Chattanooga Fleet Management Division 3102 Elmendorf Circle Chattanooga, TN 37406 Attn: Rachel Haines; 423-643-5551, rhaines@chattanooga.gov Gary Franks; 423-643-5559, gfranks@chattanooga.gov Charlotte Hicks; 423-643-5191, chicks@chattanooga.gov					
					

\*\*\*\*\* NOTICE \*\*\*\*\*

This Purchase Order ("Agreement") is a binding agreement between the City of Chattanooga and the Vendor. This Purchase Order shall be governed by the following documents: (1) Purchase Order, (2) City of Chattanooga Purchase Order Standard Terms and Conditions, (3) Vendor's response to the bid or quotation, and (4) terms and conditions set forth in the bid or quotation, each of which is hereby incorporated herein by reference and becomes a part of this Agreement. In the event any conflict of terms arises, the terms controlling the Agreement shall be in the order provided hereinabove. This Purchase Order is valid only when signed or electronically approved by the Finance Officer.

Electronic approval is on record in the purchasing information system which asserts that unencumbered appropriation is available to meet the expenditure covered by this Purchase Order and further authorizes payment upon proper certification of receipt of goods and/or services.

# Purchase Order STANDARD



City of Chattanooga  
101 East 11th Street, Suite G13  
Chattanooga, TN 37402

<b>V E N D O R</b>	Vendor Number: Vendor Alternate ID: 1132355  Waterous Company 125 Hardman Avenue S South St Paul, MN 55075
--	---

PO Date: 19-AUG-19 Buyer: Mark McKeel FOB: DESTINATION Terms: Immediate	Purchase Order Number <b>555212</b>  INVOICES: Direct invoices in DUPLICATE to the Invoice address shown below.
--	--

<b>S H I P T O</b>	Amnicola Garage, Bldg 2 3102 Elmendorf Circle Chattanooga  TN  37406
--	--

<b>I N V O I C E</b>	Accounts Payable Division City of Chattanooga 101 East 11th Street, Suite 101 Chattanooga, TN 37402
--	--

Requestor		Requisition Number		Bid Number	
Rachel Haines		189257			
Line Nbr	Item ID - Item Description	Quantity	Unit	Unit Price	Total
1	Waterous-Amnicola-S100C20C Single Stage Fire Pumps	23714.00	Dollar	\$ 1.0000	\$ 23,714.00

**TOTAL: \$ 23,714.00**

\*\*\*\*\* NOTICE \*\*\*\*\*

This Purchase Order ("Agreement") is a binding agreement between the City of Chattanooga and the Vendor. This Purchase Order shall be governed by the following documents: (1) Purchase Order; (2) City of Chattanooga Purchase Order Standard Terms and Conditions; (3) Vendor's response to the bid or quotation; and (4) terms and conditions set forth in the bid or quotation, each of which is hereby incorporated herein by reference and becomes a part of this Agreement. In the event any conflict of terms arises, the terms controlling the Agreement shall be in the order provided hereinabove. This Purchase Order is valid only when signed or electronically approved by the Finance Officer.

Electronic approval is on record in the purchasing information system which asserts that unencumbered appropriation is available to meet the expenditure covered by this Purchase Order; and further authorizes payment upon proper certification of receipt of goods and/or services.





125 Hardman Ave S.  
 South St. Paul, MN 55075-2456  
 Web: <http://www.waterousco.com>

# Quotation

Quote Number: 00031202

Date Printed: 8/7/2019

## Note: Quote Number Must Appear on Purchase Order

### Sold To

CITY OF CHATTANOOGA FLEET DIV  
 FIRE & POLICE SHOP18  
 3102 ELMENDORF CIRCLE  
 CHATTANOOGA, TN 37406

### Ship To

CITY OF CHATTANOOGA FLEET DIV  
 FIRE & POLICE SHOP  
 3102 ELMENDORF CIRCLE  
 CHATTANOOGA, TN 37406

Order Comments: FOR QUOTATION ONLY - REPLACEMENT S100C20C FOR SERIAL NUMBER 112966.

Quote Valid Until: 11/5/2019

Customer Information		
Customer No.: 08089300	Customer P.O.:	Credit Terms: NET 30
Ship Via:	Freight Terms:	EXW Point: South St. Paul, MN. USA
Lead Time: 6 Weeks	Customer Reference:	Contact Name: GARY FRANKS

Product Ordered		
Model: S100C20C	Description: S100C20C SINGLE STAGE FIRE PUMP	
Rated Capacity (U.S. GPM): 1500	Discharge Pressure (PSIG): 150	Material: Iron
Ratio: 2.27	High Press Stage Capacity (L/Min):	High Press Stage Pressure (Bar):
Low Press Stage Capacity (L/Min):	Low Press Stage Pressure (Bar):	New Pump and Transmission Model (Repl Trans Only):
Test Specification: 26001-00	Add Capacity Test (U.S.GPM): Not Required	Paint Color: Gray Primer M 4127 (Z5013-1223) per PR1532

## Product Configuration

### Product Ordered:

Qty	Model	Description
1	S100C20C	S100C20C SINGLE STAGE FIRE PUMP

### Each Product Consists of:

Qty	Item	Selection	Description	Mounting
	<b>CHASSIS INFORMATION</b>			
	Destination	CHATTANOOGA, TN		
	Elevation	685		
	Chassis Manufacturer	HME		
	Chassis Model	1871		
	Chassis Year	2003		
	Engine Model	SERIES 60		
	Rated Horsepower	430		
	Rated Horsepower RPM	2100		
	Chassis Transmission Model	HD4060P		

NOTICE OF CONDITION OF SALE: ALL QUOTATIONS, ACKNOWLEDGMENTS AND SALES BY WATEROUS ARE SUBJECT TO AND EXPRESSLY CONDITIONED ON BUYER'S ASSENT TO THE WATEROUS CONDITIONS OF SALE (FORM F-2190) PROVIDED WITH THE QUOTATION AND AVAILABLE AT <http://www.waterousco.com/company/conditions.shtml>.



125 Hardman Ave S.  
 South St. Paul, MN 55075-2456  
 Web: <http://www.waterousco.com>

# Quotation

Quote Number: 00031202

Date Printed: 8/7/2019

Qty	Item	Selection	Description	Mounting
	Calculated Surplus Horsepower	NA		
	Chassis Electrical System	12 Volt		
	<b>PRODUCT MODEL</b>			
1	Pump Model	S100		
1	Transmission Model	C20C		
1	Configured Pump and Transmission Model	S100C20C		
1	Material	Iron		
	<b>PUMP CAPACITY</b>			
1	Rated Capacity	1500		
1	Additional Capacity Test (U.S. GPM)	Not Required		
1	Pump Discharge Pressure	150		
1	Serial Plate Format	English		
1	OEM Location	Domestic		
	<b>PAINT COLOR</b>			
1	Paint Color	Gray Primer	Gray Primer M 4127 (Z5013-1223) per PR1532	
	<b>PUMP MOUNTING</b>			
1	Pump Discharge Position	Right		
1	Pump Mounting or Drive Location	Front (Input Shaft) Side		
1	Transmission Mounting Position	Vertical		
	<b>SHAFT AND SEAL</b>			
1	Pump Seal	Mechanical Seal (Standard No Charge)		
1	Pump Shaft Material	Stainless Steel		
	<b>IMPELLER</b>			
1	Impeller Flame Plating	With Flame Plating (Standard)		
1	Impeller Part No.	83012		
1	Test Spec	26001-00	8 in. Intake	
	<b>OVERHEAT PROTECTION MANAGER (OPM)</b>			
1	Overheat Protection Manager (OPM)	Not Required		
	<b>CAFS</b>			
1	CAF System	Not Required		
1	Air Distribution Manifold	Not Required		
1	Auxiliary Air Kit	Not Required		
1	Air Pressure Gauge	Not Required		
	<b>FOAM PUMP</b>			
1	Foam Pump Model	Not Required		
	<b>TRANSMISSION</b>			
1	Input Rotation	CW		

NOTICE OF CONDITION OF SALE: ALL QUOTATIONS, ACKNOWLEDGMENTS AND SALES BY WATEROUS ARE SUBJECT TO AND EXPRESSLY CONDITIONED ON BUYER'S ASSENT TO THE WATEROUS CONDITIONS OF SALE (FORM F-2190) PROVIDED WITH THE QUOTATION AND AVAILABLE AT <http://www.waterousco.com/company/conditions.shtml>.



125 Hardman Ave S.  
 South St. Paul, MN 55075-2456  
 Web: <http://www.waterousco.com>

# Quotation

Quote Number: 00031202

Date Printed: 8/7/2019

Qty	Item	Selection	Description	Mounting
1	Input Shaft	2.35-46T Spline		
1	Input Shaft Type	Input and Output Shaft		
1	Ratio	2.27		
2	End Yokes or Companion Flanges	1810 Series End Yoke		
	Cross and Bearing Kits	Not Required		
1	Tachometer Connection	Electronic Tach		
1	Tachometer Cable	Not Required		
1	Hydraulic Pump Mounting Provision	Not Required		
1	Shift Unit	Pneumatic 2017 with Interlock		
1	Shift Unit Panels	Without Panels		
	<b>PRESSURE CONTROL SYSTEM</b>			
1	Discharge Relief Valve Mounting	Not Required		
1	Intake Relief Valve 1 Mounting	Not Required		
1	Intake Relief Valve 2 Mounting	Not Required		
	<b>PRIMING SYSTEM</b>			
1	Priming Pump Mounting	Not Required		
1	Priming Valve System Type	Not Required		
	Priming Lubricant Tank	Not Required		
	Prime-Safe Lubricant	Not Required		
	<b>MAIN DRAIN VALVE</b>			
1	Main Drain Valve	Not Required		
	<b>ADDITIONAL ITEMS MOUNTED</b>			
	Pump Mounted Item 1	None	Not Ordered	
	<b>ADDITIONAL ITEMS SHIPPED LOOSE</b>			
	Shipped Loose Item 1	None	Not Ordered	
	<b>WARRANTY</b>			
1	Parts Warranty	1 Year Conditional Parts (Standard)		

Qty	Item	Selection	Description	Mounting
	<b>INTAKE</b>			
1	Connection	8 in. Grooved (Victaulic) Suction		
	Intake Screen	None	Not Ordered	

NOTICE OF CONDITION OF SALE: ALL QUOTATIONS, ACKNOWLEDGMENTS AND SALES BY WATEROUS ARE SUBJECT TO AND EXPRESSLY CONDITIONED ON BUYER'S ASSENT TO THE WATEROUS CONDITIONS OF SALE (FORM F-2190) PROVIDED WITH THE QUOTATION AND AVAILABLE AT <http://www.waterousco.com/company/conditions.shtml>.



125 Hardman Ave S.  
 South St. Paul, MN 55075-2456  
 Web: <http://www.waterousco.com>

# Quotation

Quote Number: 00031202

Date Printed: 8/7/2019

Qty	Item	Selection	Description	Mounting
	LEFT SIDE DISCHARGE			

Qty	Item	Selection	Description	Mounting
	RIGHT SIDE DISCHARGE			

Qty	Item	Selection	Description	Mounting
	ANSI FLANGE DISCHARGE			
1	Fitting	Without 5 in. ANSI Discharge Fitting (Open Flange)		

## Assembly Configuration

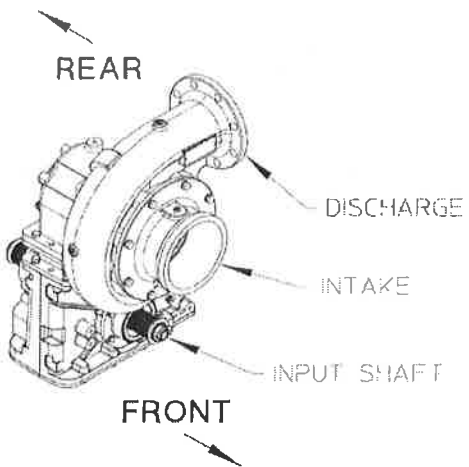

VIEWED FROM PUMP SIDE

(RIGHT DISCHARGE POSITION AS VIEWED LOOKING AT TRANSMISSION INPUT SHAFT)

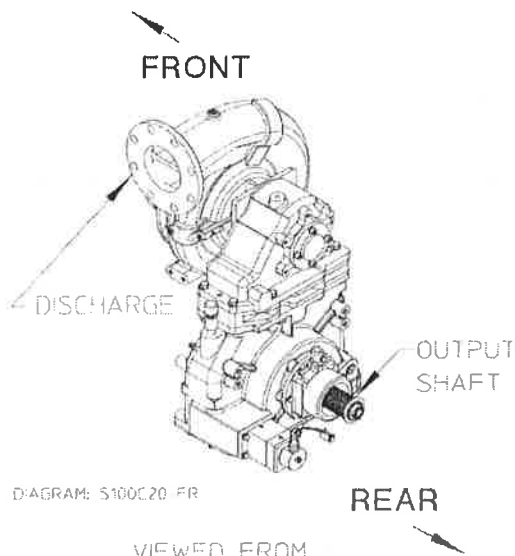

D:AGRAM: S100C20 FR

VIEWED FROM TRANSMISSION SIDE

NOTICE OF CONDITION OF SALE: ALL QUOTATIONS, ACKNOWLEDGMENTS AND SALES BY WATEROUS ARE SUBJECT TO AND EXPRESSLY CONDITIONED ON BUYER'S ASSENT TO THE WATEROUS CONDITIONS OF SALE (FORM F-2190) PROVIDED WITH THE QUOTATION AND AVAILABLE AT <http://www.waterousco.com/company/conditions.shtml>.



125 Hardman Ave S.  
South St. Paul, MN 55075-2456  
Web: <http://www.waterousco.com>

# Quotation

Quote Number: 00031202

Date Printed: 8/7/2019

Assembly Number: 82571	Pump Discharge Position: Right	Transmission Mounting Position: Vertical
Pump Discharge Flanges:	Pump Body Mounting:	Pump Mounting or Drive Location: Front (Input Shaft) Side
Input Shaft Type: Input and Output Shaft	Input Rotation: CW	Input Shaft: 2.35-46T Spline
Transmission Hydraulic Pump Flange: Not Required	Intake Side Mounting Bracket:	Bearing Housing Mtg Bracket:
Front Output Shaft:	Rear Output Shaft:	Extended Driven Shaft:



125 Hardman Ave S.  
 South St. Paul, MN 55075-2456  
 Web: <http://www.waterousco.com>

# Quotation

Quote Number: 00031202

Date Printed: 8/7/2019

## Pricing Summary

Order Quantity: 1		
Charge:	Unit Price:	Total Price:
Miscellaneous Charges	Freight	\$0.00
Net Price in U.S. Dollars		\$23,714.00

**If you have any questions concerning this order, contact.:**

Bradley Newman

651-450-5263

[banewman@waterousco.com](mailto:banewman@waterousco.com)



125 Hardman Ave S.  
 South St. Paul, MN 55075-2456  
 Web: <http://www.waterousco.com>

# Quotation

Quote Number: 00031202

Date Printed: 8/7/2019

## Conditions of Sale

### General

1. WATEROUS agrees to sell products to Buyer on the following Conditions of Sale which supersede any other or inconsistent terms of Buyer. Acceptance of orders by WATEROUS is based on the express condition that Buyer agrees to all of these Conditions of Sale. Buyer will be deemed to have assented to all Conditions of Sale contained herein if any part of the products are shipped or an invoice is presented in connection with said products. No modification or alteration of any provision hereof shall result from WATEROUS' acknowledgement of Buyer's purchase order, shipment of products or other affirmative action by WATEROUS toward performance following receipt of Buyer's purchase order or other forms containing provisions, terms or conditions in addition to or in conflict or inconsistent with these Conditions of Sale.
2. All orders or contracts resulting from written or verbal quotations or from published literature are subject to acceptance by WATEROUS. Prices, specifications, and designs included in such quotations or literature are subject to change without notice. All orders are accepted on basis that they will be billed at the price in effect on the date of shipment unless special price protection terms are offered with price increase announcements. All shipments made six months or more after the date of price increase will be billed at the price in effect on the date of shipment.
3. Prices do not include sales, use, excise or any other taxes based upon or measured by the sale, use, manufacture or shipment of the products hereby covered. All such taxes are in addition to prices quoted by WATEROUS or shown on its price list, and shall be paid by Buyer whether shown on WATEROUS' original billing or added to the billing later and, if paid by WATEROUS, the Buyer agrees to reimburse WATEROUS on demand for the full amount thereof.

### Terms of Payment

4. Terms of payment on any order are subject to approval by WATEROUS' Credit Department. Unless otherwise stated in writing by WATEROUS, terms to Buyer who have established credit satisfactory to WATEROUS are net thirty (30) days from date of date of invoice for sales in North America and net sixty (60) days from date of invoice for International sales. If Buyer fails to make payment in accordance with the terms of this agreement, the account shall be deemed to be delinquent. A service charge not exceeding the maximum allowed by law may be assessed. Buyer agrees to pay all collection costs and expenses, including reasonable attorney's fees incurred by WATEROUS in collecting or attempting to collect such account. Payment by the Buyer of the price of the order shall be a condition precedent to Buyer's right to assert any claim against WATEROUS. WATEROUS reserves the right to ship any order C.O.D.
5. Should the financial responsibility of Buyer at anytime become unsatisfactory to WATEROUS, WATEROUS shall have the right to suspend the performance of any order or require payment for any shipment hereunder in advance or require satisfactory security or other adequate assurance satisfactory to WATEROUS. If Buyer fails to make payment in accordance with the terms of this agreement or fails to comply with any provision hereof, WATEROUS may at its option, in addition to any other remedy, cancel any unshipped portion of this order with Buyer to remain liable for all unpaid accounts. WATEROUS shall have the right to credit toward the payment of any monies that may become due WATEROUS hereunder any sums which may now or hereafter be owed to Buyer by WATEROUS.
6. All shipments are F.O.B. factory, South St. Paul, Minnesota, unless otherwise stated in the order. Unless otherwise provided in writing, freight charges on all shipments, and spotting, switching, demurrage or drayage at destination are to be paid by Buyer. Any increase in the amount of freight from that shown on the face hereof as being included is for Buyer's account. WATEROUS reserves the right to designate origin and intermediate carriers. If a specific delivery carrier is required, Buyer must designate such carrier in writing to WATEROUS prior to shipment. WATEROUS reserves the right to make partial shipments. Title to products sold shall pass upon delivery to carrier at the port of shipment, irrespective of any freight allowance or prepayment of freight, and thereafter the risk of loss or damage shall be upon Buyer.

### Delay in or Prevention of Performance

7. WATEROUS shall not be liable for any expense, loss or damage resulting from delay in delivery or prevention of performance caused by fires, floods, acts of God, strikes, labor disputes, labor shortages, lack of or inability to obtain materials, fuels, supplies or equipment, riots, accidents, transportation delays, acts or failures to act of any government or of Buyer, or any other cause whatsoever, provided that such cause is beyond the reasonable control of WATEROUS, and WATEROUS shall have such additional time for performance as may be reasonably necessary under the circumstances and may adjust the price to reflect increases occasioned by such delay. Acceptance by Buyer of any product shall constitute a waiver by Buyer of any claim for damages on account of any delay in delivery of such products if delivery is delayed or interrupted by any such cause. WATEROUS may store the products at Buyer's expense and risk, and WATEROUS may charge Buyer thereof a reasonable storage rate. If WATEROUS is

(e) normal wear items (packing, strainers, filters, light bulbs, anodes, intake screens, mechanical seals, etc.)

**ALL OTHER WARRANTIES ARE EXCLUDED, WHETHER EXPRESS OR IMPLIED BY OPERATION OF LAW OR OTHERWISE, INCLUDING ALL IMPLIED WARRANTIES OF MERCHANTABILITY OR FITNESS FOR A PARTICULAR PURPOSE. IN NO EVENT, WHETHER AS A RESULT OF BREACH OF CONTRACT, WARRANTY, TORT (INCLUDING NEGLIGENCE), STRICT LIABILITY, OR ANY OTHER CAUSE OF ACTION, SHALL WATEROUS BE LIABLE FOR ANY PUNITIVE, SPECIAL, INCIDENTAL OR CONSEQUENTIAL DAMAGES, OR FOR PERSONAL INJURY OR PROPERTY DAMAGES.**

The exclusive remedy of Buyer and the sole liability of WATEROUS, whether based on contract, warranty, tort or any other basis of recovery whatsoever, is expressly limited at the election of WATEROUS to:

- (a) the replacement at the agreed point of delivery of any product or part, which upon inspection by WATEROUS or its duly authorized representative, is found not to conform to the limited warranty set forth above; or
- (b) the repair of such product or part; or
- (c) the refund or crediting to Buyer of the net sales price of the defective product or part.

**BUYER'S REMEDIES CONTAINED HEREIN ARE EXCLUSIVE OF ANY OTHER REMEDY OTHERWISE AVAILABLE TO BUYER.**

### Patents/Proprietary Information

13. In the event that any claim is made or action brought against the Buyer based on a claim that any product or part sold hereunder constitutes an infringement of any U.S. Patent, the Buyer shall notify WATEROUS immediately thereof. WATEROUS shall have the right, with the Buyer's assistance, if required, but at WATEROUS' expense, to conduct settlement negotiations or any litigation. In the event said product or parts in such action held to be an infringement of any U.S. Patent, and the use is enjoined or, as a result of a settlement, WATEROUS deems the continued use inadvisable, then provided that the Buyer has given WATEROUS the immediate notice provided for above and the product or part has been used only in accordance with the provision of this contract and shall not have been altered or changed in any material way, WATEROUS shall, at its option and expense, either procure for the Buyer the right to continue using said product or part, or repurchase same from Buyer for the original purchase price less reasonable depreciation. The foregoing states WATEROUS' entire liability for patent infringement. Notwithstanding, the foregoing, WATEROUS shall have no liability whatsoever and Buyer shall indemnify and save WATEROUS harmless from any liability, cost, claim or expense, including, without limitation, reasonable attorney's fees, arising out of or attributable to patent infringement actions for products manufactured to the Buyer's design or specification.
14. All drawings, diagrams, specifications and other materials furnished by WATEROUS and identified as confidential, relating to the manufacture, or installation, or use or service of products or parts furnished hereunder and the information therein, are proprietary to WATEROUS. Such materials have been developed at great expense, and they contain trade secrets of WATEROUS. Buyer may not reproduce or distribute such materials except to Buyer's employees who may use the materials as part of their duties. All such materials relating to the product or part supplied directly by WATEROUS (except information as may be established to be in the public domain or disclosed pursuant to judicial government action) shall be received in confidence, and Buyer shall exercise reasonable care to hold such information in confidence.

All information received by WATEROUS from the Buyer shall be deemed not to be confidential and not to involve any trade secrets unless such information is clearly identified as confidential trade secret information by the Buyer and an officer of WATEROUS has specifically signed a confidentiality agreement relating to such information. Except as above stated, representatives of WATEROUS are not authorized to accept any information from the Buyer in confidence.

### Time Limit for Causes of Action

15. All actions, regardless of form, arising out of or related to this transaction or the products sold hereunder must be commenced against WATEROUS within the applicable limitations period, but in no event more than one (1) year after the cause of action accrues.

### Indemnification

16. WATEROUS shall not be liable for any losses or damages sustained by the Buyer, or any other person, as a result of improper installation or misapplication of the product. Buyer shall defend, indemnify and hold harmless WATEROUS and its agents and employees against any loss, damage, claim, suit, liability, judgment or expense, including, without limitation, attorney's fees, arising out of or in connection with any injury, death or damage to or loss of any property

**NOTICE OF CONDITION OF SALE: ALL QUOTATIONS, ACKNOWLEDGMENTS AND SALES BY WATEROUS ARE SUBJECT TO AND EXPRESSLY CONDITIONED ON BUYER'S ASSENT TO THE WATEROUS CONDITIONS OF SALE (FORM F-2190) PROVIDED WITH THE QUOTATION AND AVAILABLE AT <http://www.waterousco.com/company/conditions.shtml>.**



125 Hardman Ave S,  
South St. Paul, MN 55075-2456  
Web: <http://www.waterousco.com>

# Quotation

Quote Number: 00031202

Date Printed: 8/7/2019

delayed in proceeding with production or otherwise because it is awaiting buyer's approval or acceptance of designs, drawings, prints, engineering or technical data, or is awaiting Buyer's approval or acceptance of the products, WATEROUS shall be entitled to an adjustment in price commensurate with any increase in WATEROUS' cost of production and any other losses and expenses incurred by WATEROUS attributable to such delays.

### Inspection and Acceptance

- 6. Claims for damage, shortage or errors in shipping must be reported within one (1) day following delivery to Buyer. Buyer shall have seven (7) days from the date Buyer receives any products to inspect such products for defects and nonconformance which are not due to damage, shortage or errors in shipping and to notify WATEROUS, in writing, of any defects, nonconformance or rejection of such products. After such seven (7) day period, Buyer shall be deemed to have irrevocably accepted the products, if not previously accepted. After such acceptance, Buyer shall have no right to reject the products for any reason or to revoke acceptance. Buyer hereby agrees that such seven (7) day period is a reasonable amount of time for such inspection and revocation.

### Returned Material

- 9. No products or parts may be returned for any reason and no order may be cancelled or changed in whole or in part without the prior written consent of WATEROUS. Special items not normally stocked by WATEROUS cannot be returned for credit unless the manufacturer of said special items agrees to accept their return for credit and the Buyer agrees to pay a handling charge of twenty five percent (25%) of invoice price plus the full restocking charge of the manufacturer.

### Cancellations - Partial/Deferred Delivery

- 10. No order or contract is subject to cancellation or change by the Buyer unless agreed to in writing by an authorized person of WATEROUS. In the event of any cancellation and without any limitation to other available remedies to WATEROUS, Buyer shall pay WATEROUS within forty (30) days of such cancellation the contract price, including applicable taxes, for all products, materials and services which have been completed prior to cancellation. Additionally, Buyer shall pay WATEROUS within thirty (30) days of such cancellation all costs and other expenses incurred by WATEROUS for uncompleted items (including without limitation all commitments to WATEROUS' suppliers, subcontractors and others) and a cancellation charge in an amount equal to twenty percent (20%) upon the total of the foregoing. In the event of any change, WATEROUS shall be entitled to revise its prices and delivery schedules to reflect such changes.
- 11. Buyer agrees to accept delivery of any part or all of the products on the mutually agreed upon delivery date and failure of Buyer to furnish WATEROUS with shipping instructions shall in no way alter the terms of payment of WATEROUS' invoice for any of the products offered for delivery. Any deferred delivery requested by Buyer shall be subject to WATEROUS' written approval. On any approved deferred delivery WATEROUS shall have the right to render invoice for the completed portion of the order and to warehouse all completed products at Buyer's expense and risk of loss, on the completed portion of the order, WATEROUS reserves the right at its option to either make a cancellation charge on the same conditions and terms of payment as outlined in Section 10, hereof or to revise its prices and delivery schedules on the uncompleted portion to reflect its increased costs, delays and expenses.

### Warranty and Limitations of Liabilities and Buyer's Remedies

- 12. WATEROUS warrants, to the original Buyer only, that products manufactured by WATEROUS will be free from defects in material and workmanship under normal use and service for the period specified in the product catalogs supplied by WATEROUS and that service parts are warranted for a period of ninety days, provided the Buyer notifies WATEROUS, in writing, of the defect in said product within the warranty period, and said product is found by WATEROUS to be nonconforming with the aforesaid warranty. When required in writing by WATEROUS, defective products must be promptly returned by Buyer to WATEROUS at WATEROUS' plant at South St. Paul, Minnesota, or at such other place as may be specified by WATEROUS, with transportation and other charges prepaid. A Returned Material Authorization (RMA) is required for all products and parts and may be requested by phone, fax, email, or mail. The aforesaid warranty excludes any responsibility or liability of WATEROUS for:
  - (a) damages or defects due to accident, abuse, misuse, abnormal operating conditions, negligence, accidental causes, or improper maintenance, or attributable to written specifications or instructions furnished by Buyer,
  - (b) defects in products manufactured by others and furnished by WATEROUS hereunder, if being understood and agreed by the parties that the only warranty provided for such products shall be the warranty provided by the manufacturer thereof which, if assignable, WATEROUS will assign to Buyer, if requested by Buyer,
  - (c) any product or part, altered, modified, serviced or repaired other than by WATEROUS, without its prior written consent,
  - (d) the cost of dismantling, removing, transporting, storing, or insuring the defective product or part and the cost of reinstallation, and

... or the environment, or violation of any applicable laws or regulations, resulting directly or indirectly from the installation or operation of any products, machinery, equipment, apparatus, components or parts (collectively "Products") furnished by WATEROUS and caused by or resulting from Buyer's negligence or other fault, or caused by or resulting from any failure of Buyer or others to specify, or install, or provide devices or warnings to protect against or prevent personal injury or other damages in connection with the installation, operation, or use of any such Products by any person, whether or not such devices or warnings are required by law or government regulation.

### Miscellaneous

- 17. Waiver of any term or provision in this agreement or of any breach of this agreement or of any term or provision hereof, shall not be construed as a waiver of any other term or provision or any other breach, nor shall any such waiver be deemed or construed as a continuing waiver of any such term, provision or breach. Any provision of this agreement prohibited by applicable law shall be ineffective to the extent of such prohibition without invalidating the remaining provisions hereof. The failure of WATEROUS to require strict performance of any provision shall not diminish WATEROUS' right hereafter to require strict performance of any provision.
- 18. These Conditions of Sale and the transaction between Buyer and WATEROUS shall be governed under and according to the laws of the State of Minnesota without regard to choice of law provisions. Any claim or action by Buyer against WATEROUS, regardless of form, arising out of or related to this agreement or transaction or the product sold hereunder shall be exclusively brought in the state or federal courts sitting in Minnesota, the personal and subject matter jurisdiction of which the Buyer irrevocably consents and submits.
- 19. In the event of a conflict between any of the printed provisions hereof and any written or typed provision hereof, the written or typed provisions shall govern. All headings are for convenience of reference only and are not part of this agreement.
- 20. Buyer may not assign this order or any rights hereunder without WATEROUS' prior written consent. These Conditions of Sale are enforceable, however, against the successors and assigns of Buyer.
- 21. WATEROUS has the right to correct any stenographical or clerical errors in any of the writings issued by it.
- 22. These Conditions of Sale shall not be construed against the party preparing them, but shall be construed as if all parties jointly prepared these Conditions of Sale and any uncertainty or ambiguity shall not be interpreted against any one party.
- 23. Buyer shall not be entitled to set-off any amounts due Buyer against any amounts due WATEROUS in connection with this agreement or transaction.
- 24. There are no terms, conditions, understandings or agreements between Buyer and WATEROUS other than those stated herein and all prior proposals and negotiations are merged herein. No agent, employee or representative of WATEROUS has any authority to bind WATEROUS by any affirmation, representation or warranty concerning the products sold under this agreement and unless the affirmation, representation or warranty made by an agent, employee or representative appears as an express warranty in this agreement, it shall not be enforceable, unless expressly appearing as a warranty written into all copies of this document, there is no express warranty of any kind. No terms or conditions in any way altering or modifying the provisions hereof shall be binding upon WATEROUS unless in writing, expressly stated as amending this agreement, and signed by an authorized representative of WATEROUS. No modification or alteration of any provision hereof shall result from WATEROUS' acknowledgement of Buyer's purchase order, shipment of material or other affirmative action by WATEROUS toward performance hereunder following receipt of Buyer's purchase order, shipping order or other forms containing provisions, terms or conditions in addition to or inconsistent with the provisions hereof.

### ANTI-CORRUPTION LAW COMPLIANCE

Waterous Company is committed to conducting all business in a fair, honest, and ethical manner. It is the policy of Waterous Company to comply with applicable laws and regulations, including the Foreign Corrupt Practices Act (FCPA), and to avoid any activities that might be considered bribery or other forms of corruption. Waterous Company will not make any payments or offer anything of value to any government official, employee, or agent to obtain or retain business. Waterous Company will not make any payments or offer anything of value to any third party to influence any government official, employee, or agent. Waterous Company will not make any payments or offer anything of value to any third party to influence any government official, employee, or agent. Waterous Company will not make any payments or offer anything of value to any third party to influence any government official, employee, or agent.

F-2190 (01/20/16)

Waterous Company, 125 Hardman Avenue South, South St. Paul, MN 55075 USA

[www.waterousco.com](http://www.waterousco.com)

NOTICE OF CONDITION OF SALE: ALL QUOTATIONS, ACKNOWLEDGMENTS AND SALES BY WATEROUS ARE SUBJECT TO AND EXPRESSLY CONDITIONED ON BUYER'S ASSENT TO THE WATEROUS CONDITIONS OF SALE (FORM F-2190) PROVIDED WITH THE QUOTATION AND AVAILABLE AT <http://www.waterousco.com/company/conditions.shtml>.





125 Hardman Ave S.  
South St. Paul, MN 55075-2456  
Web: <http://www.waterousco.com>

## Quotation

Quote Number: 00031202

Date Printed: 8/7/2019

NOTICE OF CONDITION OF SALE: ALL QUOTATIONS, ACKNOWLEDGMENTS AND SALES BY WATEROUS ARE SUBJECT TO AND EXPRESSLY CONDITIONED ON BUYER'S ASSENT TO THE WATEROUS CONDITIONS OF SALE (FORM F-2190) PROVIDED WITH THE QUOTATION AND AVAILABLE AT <http://www.waterousco.com/company/conditions.shtml>.

**Proposed City Council Purchases 09-24-2019**

DEPARTMENT REQUISITION NO.	ITEM DESCRIPTION	BIDS REQUESTED	BIDS RETURNED	LOWEST/BEST BIDDER	COST	FUND NAME	Information Requested Collected Prior to Council Session
R189334 Fire Department	Purchase - Thirty-nine (39) Defibrillators - Fire Department	6	4	CPR Savers & First Aid Supply, LLC 7904 E. Chaparral Road, Scottsdale, AZ 85250	Total Amount \$68,650.00	General Fund	Purchase - Thirty-nine (39) Defibrillators - Fire Department. There were six (6) direct bid solicitations and we received four (4) responses in the publicly advertised bid proceedings.
R189379 Fire Department	Purchase - Three (3) Fire Engine Exhaust Removal Systems - Fire Department	-	-	Air Vacuum Corporation (AIRVAC) PO Box 517 Dover, NH 03821-0517	Total Amount \$73,907.00	General Fund	Purchase - Three (3) Fire Engine Exhaust Removal Systems. Per Fire Department TCA 6-56-304.2 allows for this source purchase exempted from the usual advertising and bidding procedures.
R189007 Transportation Department	Standard Purchase - Barricade Rental -Transportation Department	4	2	Highway Markings, Inc. 9510 Maynardville Hwy Maynardville, TN 37807	Estimated \$37,500.00 Annually	General Fund	Purchase - Barricade Rental -Transportation Department. There were four (4) direct bid solicitations and we received two (2) responses in the publicly advertised bid proceedings.
PO552002 Youth & Family Development Department	Blanket Contract Renewal - Floor Care Services - Department of Youth & Family Development, Head Start Centers	6	3	Alturative Source P.O. Box 514 Oolteway, TN 37363	Estimated \$33,000.00 Annually	General Fund	Blanket Contract Renewal - Floor Care Services - Department of Youth & Family Development/Head Start Centers. This will be the first (1st) contract renewal for twelve (12) months with the option to renew one (1) additional twelve (12) month term. There were six (6) direct bid solicitations and we received three (3) responses in the publicly advertised bid proceedings.
R190064 Public Works Department	Purchase - One (1) Toro Groundsmaster 3505-D Mower & Two (2) Toro Workman GTX EFI Bucket Utility - Parks Division - Public Works Department	-	-	Smith Turf & Irrigation 525 Fairground Court Nashville, TN 37211	Total Amount \$48,195.00	General Fund	Purchase - Four (4) Henderson Stainless Steel Salt Spreader - City Wide Services Division - Public Works Department. This purchase is using the State of Tennessee Contract No SWC242-45200. TCA 6-56-304.2 allows for this single source purchase exempted from the usual advertising and bidding procedures.

PO551958 Public Works Department	Blanket Contract Renewal - Youth Athletic Association Baseball Field Renovations - Parks Division - Public Works Department	14	2	River City Athletic Fields P.O. Box 685 Soddy Daisy, TN 37379	Estimated \$115,000.00 Annually	General Fund	Blanket Contract Renewal - Youth Athletic Association Baseball Field Renovations - Parks Division - Public Works Department. The City of Chattanooga is renewing the first (1st) contract renewal for twelve (12) months with the option for one (1) additional twelve (12) month term.
PO552038 Public Works Department	Blanket Contract Renewal - Playground Inspection Services - Parks Division - Public Works Department	9	2	Playground Guardian, LLC P.O. Box 240981 Charlotte, NC 28224	Estimated \$45,000.00 Annually	General Fund	Blanket Contract Renewal - Playground Inspection Services - Parks Division - Public Works Department, The City of Chattanooga is renewing the first (1st) contract renewal for twelve (12) months with the option for one (1) additional twelve (12) month term.
PO538199 Public Works Department	Blanket Contract Renewal - Knoll Open Office Landscape Furniture - City Wide - Facilities Management Division - Public Works Department			CBI 701 Cherry Street, Suite 100 Chattanooga, TN 37402	Estimated \$250,000.00 Annually	General Fund	Blanket Contract Renewal - Knoll Open Office Landscape Furniture - City Wide - Facilities Management Division - Public Works Department. The City of Chattanooga is renewing the fourth (4th) and final contract renewal for twelve (12) months. This blanket contract is from the Omnia Partners, formerly U.,S. Communities, to Knoll Inc. using CBI who is authorized dealer for Knoll. TCA 6-56-304.2 allows this single source blanket contract exempted from the usual advertising and bidding requirements.
PO551823 Public Works Department	Blanket Contract Renewal - Setina Police Vehicle Equipment - Fleet Division - Public Works Department	7	5	Lee-Smith, Inc. 2600 8th Street Chattanooga, TN 37407	Estimated \$100,000.00 Annually	General Fund	Blanket Contract Renewal - Setina Police Vehicle Equipment - Fleet Division - Public Works Department. The City of Chattanooga is renewing the first (1st) contract renewal for twelve (12) months with the option for one (1) additional twelve (12) month term.
PO552015 Public Works Department	Blanket Contract Renewal - Irrigation System Repair Services - Parks Division - Public Works Department	8	3	Lawn Pros of Chattanooga PO Box 21892 Chattanooga, TN 37424	Estimated \$35,000.00 Annually	General Fund	Blanket Contract Renewal - Irrigation System Repair Services - Parks Division - Public Works Department. The City of Chattanooga is renewing the first (1st) contract renewal for twelve (12) months with the option for one (1) additional twelve (12) month term.
PO552043 Public Works Department	Blanket Contract Renewal - Manhole Inspection Services - Waste Resources Division - Public Works Department	11	11	Compliance EnviroSystems, LLC 1401 Seaboard Drive Baton Rouge, LA 70810	Estimated \$250,000.00 Annually	Interceptor Sewer	Blanket Contract Renewal - Irrigation System Repair Services - Parks Division - Public Works Department. The City of Chattanooga is renewing the first (1st) contract renewal for twelve (12) months with the option for one (1) additional twelve (12) month term.

R189118 Public Works Department	New Blanket Contract - Tire Disposal & Recycling Services - City Wide Services Division - Public Works Department	7	2	Liberty Tire Recycling 1700 Transport Way, Knoxville, TN 37924	Estimated \$30,000.00 Annually	General Fund	New Blanket Contract - Tire Disposal & Recycling Services - City Wide Services Division - Public Works Department. The City of Chattanooga will issue a contract for twelve (12) months with the option to renew for two (2) additional twelve (12) month terms. There were seven (7) direct bid solicitations and we received two (2) responses in the publicly advertised bid proceedings.
R189370 Public Works Department	Purchase - One (1) Combustion Total Organic Carbon (TOC) Analyzer - Waste Resources Division - Public Works Department	3	2	Government Scientific Source, Inc. 12351 Sunrise Valley Drive Reston, VA 20191	Total Amount \$44,157.00	Interceptor Sewer	Purchase - One (1) Combustion Total Organic Carbon (TOC) Analyzer - Waste Resources Division - Public Works Department. There were three (3) direct bid solicitations and we received two (2) responses in the publicly advertised bid proceedings.
R184631 Public Works Department	New Blanket Contract - Floor Cleaning Services for City Hall Campus - Facilities Management Division - Public Works Department	7	4	Jani-King of Chattanooga 7610 Hamilton Park Drive, Suites 3 & 4 Chattanooga, TN 37421	Estimated \$325,000.00 Annually	General Fund	New Blanket Contract - Floor Cleaning Services for City Hall Campus - Facilities Management Division - Public Works Department. The City of Chattanooga will issue a contract for twelve (12) months with the option to renew for two (2) additional twelve (12) month terms. There were seven (7) direct bid solicitations and we received four (4) responses in the publicly advertised bid proceedings.



# City of Chattanooga

Mayor Andy Berke

September 16, 2019

Chief Phillip Hyman  
Chattanooga Fire Department  
910 Wisdom Street  
Chattanooga, TN 37406

Subject: 189334/305637 – Defibrillators – Chattanooga Fire Department

Dear Chief Hyman:

Council approval is recommended for the purchase of thirty-nine (39) Defibrillators. These Defibrillators will be used by the Chattanooga Fire Department.

The invitation to bid was sent to six (6) vendors as well as formally advertised. Four (4) responses were received as shown below. A spreadsheet has been prepared and attached for your review and consideration. Copies of the actual bids are retained on file in the Purchasing Office for your review upon request.

<u>Bidders</u>	<u>Bid Amount</u>
School Health Corporation	\$92,329.00
Stryker	\$86,309.00
Green Guard First Aid	\$78,020.00
CPR Savers & First Aid Supply, LLC	\$68,650.00

September 16, 2019

Page 2

**Subject: 189334/305637 – Defibrillators – Chattanooga Fire Department**

**I recommend awarding this contract in the amount of \$68,650.00 to CPR Savers & First Aid Supply, LLC as the best bid meeting specifications for the City of Chattanooga.**

Respectfully yours,



**Bonnie Woodward,  
Purchasing Director**

**BW/DP  
Attachments**

**Vendor Information:  
CPR Savers & First Aid Supply, LLC  
7904 E. Chaparral Road, Suite A110-242  
Scottsdale, AZ 85250**



# BID SOLICITATION



**City of Chattanooga**  
 101 East 11th Street, Suite G13  
 Chattanooga, TN 37402

<b>BID OPENING DATE AND TIME:</b> 09-SEP-19 at 2:00 PM  <b>BID NUMBER: 305637</b>
<b>BUYER:</b> PHONE #: (423) 643-7230 DELIVERY REQUIRED:

**SEALED BIDS**

Mail or submit two (2) signed copies of bid form to this office in the enclosed envelope. Retain one copy for your file.

<b>V E N D O R</b>	RFQ
--	-----

<b>M A I L T O</b>	City of Chattanooga 101 East 11th Street, Suite G13 Chattanooga, TN 37402
--	---

Item	Class-Item	Quantity	Unit	Unit Price	Total
Requisition No.: 189334 Ordering Dept.: Chattanooga Fire Department Buyer: Dedra Partridge Phone No.: (423) 643-7237  Item(s) Being Purchased: Defibrillators  ATTACHMENTS: Lifepak 1000 Automatic External Defibrillators Specificatoins Instructions To Bidders Iran Divestment Act Form No Contact/No Advocacy Affidavit Affirmative Action Plan City of Chattanooga (COC) Terms and Conditions posted on Website <a href="http://www.chattanooga.gov/purchasing/standard-terms-and-conditions">http://www.chattanooga.gov/purchasing/standard-terms-and-conditions</a> If you can't download call buyer for a copy.  *** BID MUST BE RECEIVED NO LATER THAN *** *** 2:00 PM EST ON September 9, 2019 ***  NOTE: ALL BIDS MUST BE SIGNED All bids received are subject to the terms and conditions contained herein and as listed in the above referenced website. The undersigned Bidder acknowledges having received, reviewed, and agrees to be bound to these terms and conditions, unless specific written exceptions are otherwise stated.  Any manufacturer;s names, trade names, brand names, or catalog numbers used in the specifications are for the purpose of describing and establishing general quality levels. Such references ar enot intended to be restrictive. Bids will be considered for any brand which meets or exceeds the quality of the specifications listed for any item  The City of Chattanooga reserves the right to reject any and/or all bids, waive any informalities in the bids received, and to accept any bid which in its opinion may be for the best interest of the city.  The City of Chattanooga wil: be non-discriminatory in the purchase of all goods and services on the basis of race, color, or national origin  **** NOTE **** PLEASE PROVIDE US WITH THE FOLLOWING INFORMATION:  Company Name <u>CPR Savers &amp; First Aid Supply LLC</u> Address <u>7904 E. Chaparral Rd</u> <u>Ste A110-242</u> <u>Scottsdale, AZ 85250</u>  Phone/Toll-Free No. <u>800-480-1277</u> Fax No. <u>480-422-8521</u> eMail Address <u>darryl@cpr-savers.com</u>					



# BID SOLICITATION



City of Chattanooga  
 101 East 11th Street, Suite G13  
 Chattanooga, TN 37402

<b>BID OPENING DATE AND TIME:</b> 09-SEP-19 at 2:00 PM  <b>BID NUMBER:</b> 305637
<b>BUYER:</b> PHONE #: (423) 643-7230 DELIVERY REQUIRED:

**SEALED BIDS**

Mail or submit two (2) signed copies of bid form to this office in the enclosed envelope. Retain one copy for your file.

V E N D O R	RFQ
----------------------------	-----

M A I L T O	City of Chattanooga 101 East 11th Street, Suite G13 Chattanooga, TN 37402
----------------------------	---

Item	Class-Item	Quantity	Unit	Unit Price	Total
Contact Person's Name <u>Darryl Cooper</u> Estimated Delivery <u>21 to 30 DAYS A.R.O</u> Minority-Owned Business _____ Small Business _____ Veteran _____ Minorily Woman-Owned Business _____ Disabled Veteran _____ Woman-Owned Business _____ **** ALL ITEMS MUST BE QUOTED F.O.B. DESTINATION ****					

NOTE: ALL BIDS RECEIVED ARE SUBJECT TO THE TERMS AND CONDITIONS

The City is Exempt from all Federal and State Tax.  
 Bids will be received at the above mentioned address.

TERMS OF PAYMENT: Net 30  
 TELEPHONE NUMBER: 800-480-1277

ALL BIDS MUST BE SIGNED - The undersigned offers the above quoted prices under the conditions contained herein.

COMPANY: CPR Savers & First Aid Supply  
 SIGNATURE: Darryl Cooper  
 NAME AND TITLE: Darryl Cooper / Gov't Sales

# BID SOLICITATION



City of Chattanooga  
 101 East 11th Street, Suite G13  
 Chattanooga, TN 37402

<b>BID OPENING DATE AND TIME:</b> 09-SEP-19 at 2:00 PM <b>BID NUMBER: 305637</b>
<b>BUYER:</b> PHONE #: (423) 643-7230 DELIVERY REQUIRED:

**SEALED BIDS**

Mail or submit two (2) signed copies of bid form to this office in the enclosed envelope. Retain one copy for your file.

V  
E  
N  
D  
O  
R

RFQ

M  
A  
I  
L  
T  
O

City of Chattanooga  
 101 East 11th Street, Suite G13  
 Chattanooga, TN 37402

Item	Class-Item	Quantity	Unit	Unit Price	Total
1	Lifepak 1000 Automatic External Defibrillators	35	Each	<u>1850.00</u>	<u>64,750.00</u>
2	Lifepak Trainer 1000 Automatic External Defibrillators	4	Each	<u>975.00</u>	<u>3900.00</u>

NOTE: ALL BIDS RECEIVED ARE SUBJECT TO THE TERMS AND CONDITIONS

The City is Exempt from all Federal and State Tax.  
 Bids will be received at the above mentioned address.

TERMS OF PAYMENT: Net 30

TELEPHONE NUMBER: 800-480-1277

ALL BIDS MUST BE SIGNED – The undersigned offers the above quoted prices under the conditions contained herein.

CPR Savers & First Aid Supply

COMPANY: \_\_\_\_\_

SIGNATURE: Darryl Cooper

NAME AND TITLE: Darryl Cooper

PRICE SUBMITTAL: Physio-Control Lifepak 1000 AED Units

Company Name CPR Savers & First Aid Supply

PRICE STRUCTURE – Complete the following and include associated information specifics for the cost quoted (additional pages may be used as needed). Prices are to include all shipping and handling.

**Description** Cost  
Lifepak 1000 AED unit package: ..... \$ 1850.00  
Includes: standard setup, soft carry case w/shoulder strap, Lithium-ion rechargeable battery, Battery Charger Kit, two (2) sets adult electrodes.

Total unit price per LP1000 AED package: ..... \$ 1850.00 <sup>dc</sup>

Total price for thirty-five (35) LP1000 AED packages: ..... \$ 64,750.00

Warranty on Unit: 5 Years

Warranty on Battery/Battery Life: 4 Years

Trainer 1000 AED unit package: ..... \$ 975.00

Includes: standard setup, soft carry case w/shoulder strap, wireless remote control, rechargeable Lithium-ion battery, Battery Charger, and two (2) sets training Electrodes.

Total unit price per Trainer 1000 AED package: ..... \$ 975.00

Total price for four (4) Trainer 1000 AED packages: ..... \$ 3900.00

Warranty on Unit: 2 Years

Warranty on Battery/Battery Life: 2 Years

Delivery Timetable: 21 to 30 Days A.R.O.

Additional items:

Adult electrode assembly packs: ..... \$ 43.00

Replacement rechargeable battery pack: ..... \$ 377.00

Trade In Value for G3 AED: ..... \$ 125.00/unit

Trade In Value for G3 PRO AED: ..... \$ 175.00/unit

Additional comments/recommendations:  
\_\_\_\_\_  
\_\_\_\_\_  
\_\_\_\_\_



# City of Chattanooga

Mayor Andy Berke

September 12, 2019

Chief Phillip Hyman  
Chattanooga Fire Department  
910 Wisdom Street  
Chattanooga, TN 37406

**Subject: 189379 – Fire Engine Exhaust Removal System – Chattanooga Fire Department**

Dear Chief Hyman:

Council approval is recommended to issue a purchase order for the Fire Engine Exhaust Removal System for use by the Chattanooga Fire Department.

Air Vacuum Corporation (AIRVAC), located in Dover, New Hampshire, is the manufacturer of the AIR VAC-911 Engine Exhaust Air Filtration System. The amount of this purchase will be \$73,907.00. A sole source memorandum from the Department Deputy Administrator and three (3) written quotations from AIRVAC are attached for your review.

TCA 6-56-304.2 allows for this single source purchase /repair exempted from the usual advertising and bidding procedures.

Respectfully yours,

Bonnie Woodward  
Director of Purchasing

BW: dp  
Attachments



# City of Chattanooga

Fire Department

Phil Hyman  
Fire Chief

910 Wisdom Street  
Chattanooga, Tennessee

Andy Berke  
Mayor

September 12, 2019

Bonnie Woodward  
Purchasing Director  
City of Chattanooga  
101 E. 11th Street  
Chattanooga, TN 37402

Re: Request to purchase exhaust removal systems

Dear Ms. Woodward,

The Chattanooga Fire Department is requesting to purchase three Fire Engine Exhaust Removal Systems for Stations 13 (Brainerd), 19 (Hixson), and 21 (East Brainerd). This purchase is a continuation of a plan to equip all fire stations with the new type of exhaust removal system, which has been installed in all of the newer fire stations. The replacement plan will occur as funding allows. These systems are much better at removing the apparatus exhaust from the bays than the older systems currently in stations, which require a human element of attaching hoses to the apparatus. The new, "air-scrubbing" system removes up to 98.2% of carcinogens in diesel exhaust. The vendor for this purchase is AirVac Systems, which is the only vendor for this type of system. The total price for this purchase is \$73,907.00.

Thank you for helping us move the Chattanooga Fire Department forward and creating a safer environment for our employees.

In Service,

**Seth Miller**

Executive Deputy Chief  
Chattanooga Fire Department  
423-643-5674  
srmiller@chattanooga.gov



air vacuum corporation

The World Leader In Engine Exhaust Removal Systems for the Fire and EMS Industry

Thursday, September 12, 2019

Steve Harvey  
Chattanooga Fire Hall #1  
218 East Main Street  
Chattanooga, TN 37412  
United States

Dear Steve,

This letter is to confirm our conversation regarding the availability of the AIRVAC 911® exhaust removal system for Fire & EMS Facilities.

The multi-directional airflow (vertical & horizontal) AIRVAC 911® System is manufactured and distributed solely by the Air Vacuum Corporation of Dover, New Hampshire. To the best of our knowledge there are no other manufacturers within the industry, selling or distributing, this type of exhaust removal system.

Thank you again for your interest, and please feel free to contact us if you have any additional questions.

Sincerely,

Tom Vitko  
Regional Sales Manager  
800-540-7264  
Email: [sales@airvacuumcorporation.com](mailto:sales@airvacuumcorporation.com)



GS-07F-0437M



MEETS NFPA 1500 9-1.6, OSHA, NIOSH, FEMA & MORE



The World Leader In Engine Exhaust Removal Systems for the Fire and EMS Industry

## PRICE QUOTATION – STATION #13 (2019)

Supervisor Steve Harvey Chattanooga Fire Hall #13 , Chattanooga, TN 37412	DATE: 8/14/2019 PHONE: (423) 316-7440 FAX: (423) 643-5684
---	---

DESCRIPTION	QUANTITY	UNIT COST	TOTALS
AIRVAC 911® EXHAUST REMOVAL SYSTEM - Single Ph. 115V	3	\$3,675.00	\$11,025.00
AIRVAC 911® FILTER PACK (4-Stage Filter Pack, "Main Filters")	3	\$410.00	\$1,230.00
AIRVAC 911® FILTER GAUGE (Min. one per building section)	1	\$125.00	\$125.00
UL 508A CERTIFIED CONTROL PANEL - AVEC-4C	1	\$1,099.00	\$1,099.00
ACTIVATION PACKAGE - PB030TK 200' PHOTO EYE (set) & N50SAUTM/STX01 TRACK MOUNTED DOOR SWITCH	2	\$255.00	\$510.00
	4	\$46.00	\$184.00
PREFILTERS (12 Per Box/Change date est. indicated below)	12	\$8.75	\$105.00
*ESTIMATED INSTALLATION "TURN-KEY" & DELIVERED	3	\$2,250.00	\$6,750.00
			<b>\$21,028.00</b>

\*\*Non-Schedule Item"

**MADE IN THE USA**

- ◆ *FREIGHT: FOB Origin*, ◆ **TERMS: 1/2 Payment with the order & final payment prior to release.** ◆ *Lead-Time 8 to 10 weeks.*
- ◆ Buyer is responsible for all permits, permit fees, State/local licensing fees and applicable taxes related to the purchase of product, shipping and installation or must provide all necessary tax-exempt certificates; state, local and/or county to Air Vacuum Corporation. ◆ Governmental Purchases please consult your sales rep for GSA price list.

The AIRVAC 911® System is Provided With a FIVE YEAR WARRANTY On ALL Components (excluding consumable filters)

DIAGRAM OF UNIT POSITIONING NOT AVAILABLE AT THIS TIME

Approximate Filter Life Expectancy

Prefilters 2-4 months, Main filters 12 to 24+ months.

This quotation has been prepared By: Thomas J. Vitko Date: 8/14/2019  
*Quotation Prices are valid for 90 calendar days from quotation date.*



The World Leader In Engine Exhaust Removal  
Systems for the Fire and EMS Industry

## PRICE QUOTATION – STATION #19 (2019)

Supervisor: Steve Harvey  
Chattanooga Fire Station #19  
3250 8th Avenue, Chattanooga, TN 37407

DATE: 8/14/2019  
PHONE: (423) 316-7440  
FAX: (423) 643-5684

DESCRIPTION	QUANTITY	UNIT COST	TOTALS
AIRVAC 911® EXHAUST REMOVAL SYSTEM - Single Ph. 115V	4	\$3,675.00	\$14,700.00
AIRVAC 911® FILTER PACK (4-Stage Filter Pack, "Main Filters")	4	\$410.00	\$1,640.00
AIRVAC 911® FILTER GAUGE (Min. one per building section)	1	\$125.00	\$125.00
UL 508A CERTIFIED CONTROL PANEL - AVEC-4C	1	\$1,099.00	\$1,099.00
ACTIVATION PACKAGE - PB030TK 200' PHOTO EYE (set) & N505AUTM/STX01 TRACK MOUNTED DOOR SWITCH	2	\$255.00	\$510.00
	4	\$46.00	\$184.00
PREFILTERS (12 Per Box/Change date est. indicated below)	12	\$8.75	\$105.00
*ESTIMATED INSTALLATION "TURN-KEY" & DELIVERED	4	\$2,250.00	\$9,000.00
			<b>\$27,363.00</b>

\*"Non-Schedule Item"

**MADE IN THE USA**

- ♦ *FREIGHT: FOB Origin.* ♦ **TERMS: 1/2 Payment with the order & final payment prior to release.** ♦ *Lead-Time 8 to 10 weeks.*
- ♦ Buyer is responsible for all permits, permit fees, State/local licensing fees and applicable taxes related to the purchase of product, shipping and installation or must provide all necessary tax-exempt certificates; state, local and/or county to Air Vacuum Corporation. ♦ Governmental Purchases please consult your sales rep for GSA price list.

The AIRVAC 911® System is Provided With a FIVE YEAR WARRANTY On ALL Components (excluding consumable filters)

DIAGRAM OF UNIT POSITIONING NOT AVAILABLE AT THIS TIME

Approximate Filter Life Expectancy

Prefilters 2-4 months, Main filters 12 to 24+ months.

This quotation has been prepared By: Thomas J. Vitko Date: 8/14/2019  
Quotation Prices are valid for 90 calendar days from quotation date.





The World Leader In Engine Exhaust Removal  
Systems for the Fire and EMS Industry

## PRICE QUOTATION – STATION #21 (2019)

Supervisor Steve Harvey Chattanooga Fire Station #19 3250 8th Avenue, Chattanooga, TN 37407	DATE: 8/15/2019 PHONE: (423) 316-7440 FAX: (423) 643-5684
---	---

DESCRIPTION	QUANTITY	UNIT COST	TOTALS
AIRVAC 911® EXHAUST REMOVAL SYSTEM - Single Ph. 115V	4	\$3,675.00	\$14,700.00
AIRVAC 911® FILTER PACK (4-Stage Filter Pack, "Main Filters")	4	\$410.00	\$1,640.00
AIRVAC 911® FILTER GAUGE (Min. one per building section)	1	\$125.00	\$125.00
UL 508A CERTIFIED CONTROL PANEL - AVEC-4C	1	\$1,099.00	\$1,099.00
ACTIVATION PACKAGE - PB030TK 200' PHOTO EYE (set) & N505AUTM/STX01 TRACK MOUNTED DOOR SWITCH	2	\$255.00	\$510.00
	6	\$46.00	\$276.00
PREFILTERS (12 Per Box/Change date est. indicated below)	12	\$8.75	\$105.00
*ESTIMATED INSTALLATION "TURN-KEY" & DELIVERED	4	\$1,765.25	\$7,061.00
			<b>\$25,516.00</b>

\*\*Non-Schedule Item"

**MADE IN THE USA**

- ◆ *FREIGHT: FOB Origin.* ◆ **TERMS: 1/2 Payment with the order & final payment prior to release.** ◆ *Lead-Time 8 to 10 weeks.*
- ◆ Buyer is responsible for all permits, permit fees, State/local licensing fees and applicable taxes related to the purchase of product, shipping and installation or must provide all necessary tax-exempt certificates; state, local and/or county to Air Vacuum Corporation. ◆ Governmental Purchases please consult your sales rep for GSA price list.

The AIRVAC 911® System is Provided With a FIVE YEAR WARRANTY On ALL Components (excluding consumable filters)

DIAGRAM OF UNIT POSITIONING NOT AVAILABLE AT THIS TIME

\*INSTALLATION PRICE AND SHIPPING IS CONTINGENT UPON RECEIVING ORDERS FOR STATIONS 13 & 19 AT THE SAME TIME.

Approximate Filter Life Expectancy

Prefilters 2-4 months, Main filters 12 to 24+ months.

This quotation has been prepared By: Thomas J. Vitko Date: 8/15/2019  
Quotation Prices are valid for 90 calendar days from quotation date.



# City of Chattanooga

Mayor Andy Berke

September 16, 2019

Mr. Blythe Bailey  
Administrator  
Transportation Department  
1250 Market Street, Suite 3000  
Chattanooga TN, 37402

Subject: 189007/305639 – Barricade Rental – Chattanooga Department Of Transportation

Dear Mr. Bailey:

Council approval is recommended to issue a contract for Barricade Rental for Chattanooga Department Of Transportation. The estimated expenditure under this contract is \$37,500.00.

The invitation to bid was sent to four (4) vendors as well as formally advertised. Two (2) responses were received as shown below and on the attachment. Copies of the actual bids are retained on file in the Purchasing Office for your review upon request.

<u>Bidders</u>	<u>Bid Amount</u>
A - 1 Barricades	\$65,000.00
Highway Markings, Inc.	\$37,500.00

I recommend awarding this contract to Highway Markings, Inc., 9510 Maynardville Hwy, Maynardville, TN 37807 as the best bid meeting specifications for the City of Chattanooga.

Respectfully yours,

A handwritten signature in blue ink that reads "Bonnie Woodward".

Bonnie Woodward  
Purchasing Director

BW/dp  
Attachments



# BID SOLICITATION



**City of Chattanooga**  
 101 East 11th Street, Suite G13  
 Chattanooga, TN 37402

**BID OPENING DATE AND TIME:**  
 04-SEP-19 at 2:00 PM

**BID NUMBER:** 305639

**BUYER:**  
**PHONE #:** (423) 643-7230  
**DELIVERY REQUIRED:**

**SEALED BIDS**

Mail or submit two (2) signed copies of bid form to this office in the enclosed envelope. Retain one copy for your file.

**V**  
**E** RFQ  
**N**  
**D**  
**O**  
**R**

**M** City of Chattanooga  
**A** 101 East 11th Street, Suite G13  
**J** Chattanooga, TN 37402  
**L**  
**T**  
**O**

Item	Class-Item	Quantity	Unit	Unit Price	Total
------	------------	----------	------	------------	-------

Requisition No.: 189007  
 Ordering Dept.: Transportation Department  
 Buyer: Dedra Partridge  
 Phone No.: (423) 643-7237

Items Being Purchased: Temporary Traffic Control Signal Rental

**ATTACHMENTS:**  
 Specifications Temporary Traffic Control Signal Rental  
 Instructions To Bidders  
 Iran Divestment Act Form  
 No Contact/No Advocacy Affidavit  
 Affirmative Action Plan  
 City of Chattanooga (COC) Terms and Conditions posted on Website  
<http://www.chattanooga.gov/purchasing/standard-terms-and-conditions>  
 If you can't download call buyer for a copy.

\*\*\* BID MUST BE RECEIVED NO LATER THAN \*\*\*  
 \*\*\* 2:00 PM EST ON SEPTEMBER 4, 2019

**NOTE:**  
 ALL BIDS MUST BE SIGNED  
 All bids received are subject to the terms and conditions contained herein and as listed in the above referenced website. The undersigned Bidder acknowledges having received, reviewed, and agrees to be bound to these terms and conditions, unless specific written exceptions are otherwise stated.

Any manufacturer's names, trade names, brand names, or catalog numbers used in the specifications are for the purpose of describing and establishing general quality levels. Such references are not intended to be restrictive. Bids will be considered for any brand which meets or exceeds the quality of the specifications listed for any item.

The City of Chattanooga reserves the right to reject any and/or all bids, waive any informalities in the bids received, and to accept any bid which in its opinion may be for the best interest of the city.

The City of Chattanooga will be non-discriminatory in the purchase of all goods and services on the basis of race, color, or national origin.

\*\*\*\* NOTE \*\*\*\*  
 PLEASE PROVIDE US WITH THE FOLLOWING INFORMATION:

Company Name Highway Markings, Inc.  
 Address 9510 Maynardville Hwy  
Maynardville, TN 37807  
 Phone/Toll-Free No. 865-922-9229  
 Fax No. 865-922-9238  
 eMail Address diane@highwaymarkings.com  
Gary@highwaymarkings.com

# BID SOLICITATION



City of Chattanooga  
101 East 11th Street, Suite G13  
Chattanooga, TN 37402

<b>BID OPENING DATE AND TIME:</b> 04-SEP-19 at 2:00 PM
<b>BID NUMBER:</b> 305639
<b>BUYER:</b> PHONE #: (423) 643-7230 DELIVERY REQUIRED:

**SEALED BIDS**  
Mail or submit two (2) signed copies of bid form to this office in the enclosed envelope. Retain one copy for your file.

V  
E  
N  
D  
O  
R

RFQ

M City of Chattanooga  
A 101 East 11th Street, Suite G13  
I Chattanooga, TN 37402  
L  
T  
O

Item	Class-Item	Quantity	Unit	Unit Price	Total
Contact Person's Name <u>Gary Hibben</u>					
Estimated Delivery <u>7 Days A.R.O.</u>					
Minority-Owned Business _____ Small Business <input checked="" type="checkbox"/> Veteran _____					
Minority Woman-Owned Business _____ Disabled Veteran _____					
Woman-Owned Business _____					
**** ALL ITEMS MUST BE QUOTED F.O.B. DESTINATION ****					

NOTE: ALL BIDS RECEIVED ARE SUBJECT TO THE TERMS AND CONDITIONS

The City is Exempt from all Federal and State Tax.  
Bids will be received at the above mentioned address

TERMS OF PAYMENT: NET 30 DAYS

TELEPHONE NUMBER: 865-922-9229

ALL BIDS MUST BE SIGNED – The undersigned offers the above quoted prices under the conditions contained herein.

COMPANY: Highway Markings, Inc.

SIGNATURE: Gary Hibben

NAME AND TITLE: Gary Hibben President

# BID SOLICITATION



City of Chattanooga  
101 East 11th Street, Suite G13  
Chattanooga, TN 37402

<b>BID OPENING DATE AND TIME:</b> 04-SEP-19 at 2:00 PM  <b>BID NUMBER: 305639</b>
<b>BUYER:</b> PHONE #: (423) 643-7230 DELIVERY REQUIRED:

SEALED BIDS

Mail or submit two (2) signed copies of bid form to this office in the enclosed envelope. Retain one copy for your file.

V  
E  
N  
D  
O  
R

RFQ

M  
A  
I  
L  
T  
O

City of Chattanooga  
101 East 11th Street, Suite G13  
Chattanooga, TN 37402

Item	Class-Item	Quantity	Unit	Unit Price	Total
1	Temporary Traffic Control Signal Set, 9 month minimum	9	Each	3,750.00	33,750.00
2	Temporary Traffic Control Signal Set after 9 months, Month to Month	1	Each	3,750.00	3,750.00

\* THIS UNIT THAT WE ARE QUOTING IS FAR SUPERIOR AND MORE FEATURES THAN THE UNIT THAT IS SPECIFIED.

NOTE: ALL BIDS RECEIVED ARE SUBJECT TO THE TERMS AND CONDITIONS

The City is Exempt from all Federal and State Tax.  
Bids will be received at the above mentioned address.

TERMS OF PAYMENT: NET-30 Days

TELEPHONE NUMBER: 865-922-9229

ALL BIDS MUST BE SIGNED – The undersigned offers the above quoted prices under the conditions contained herein.

COMPANY Highway Markings Inc  
 SIGNATURE: Amy Hibben  
 NAME AND TITLE Gary Hibben President

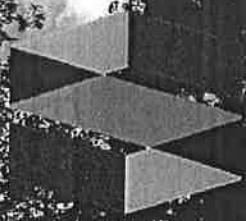

# SUPERIOR TRAFFIC SERVICES

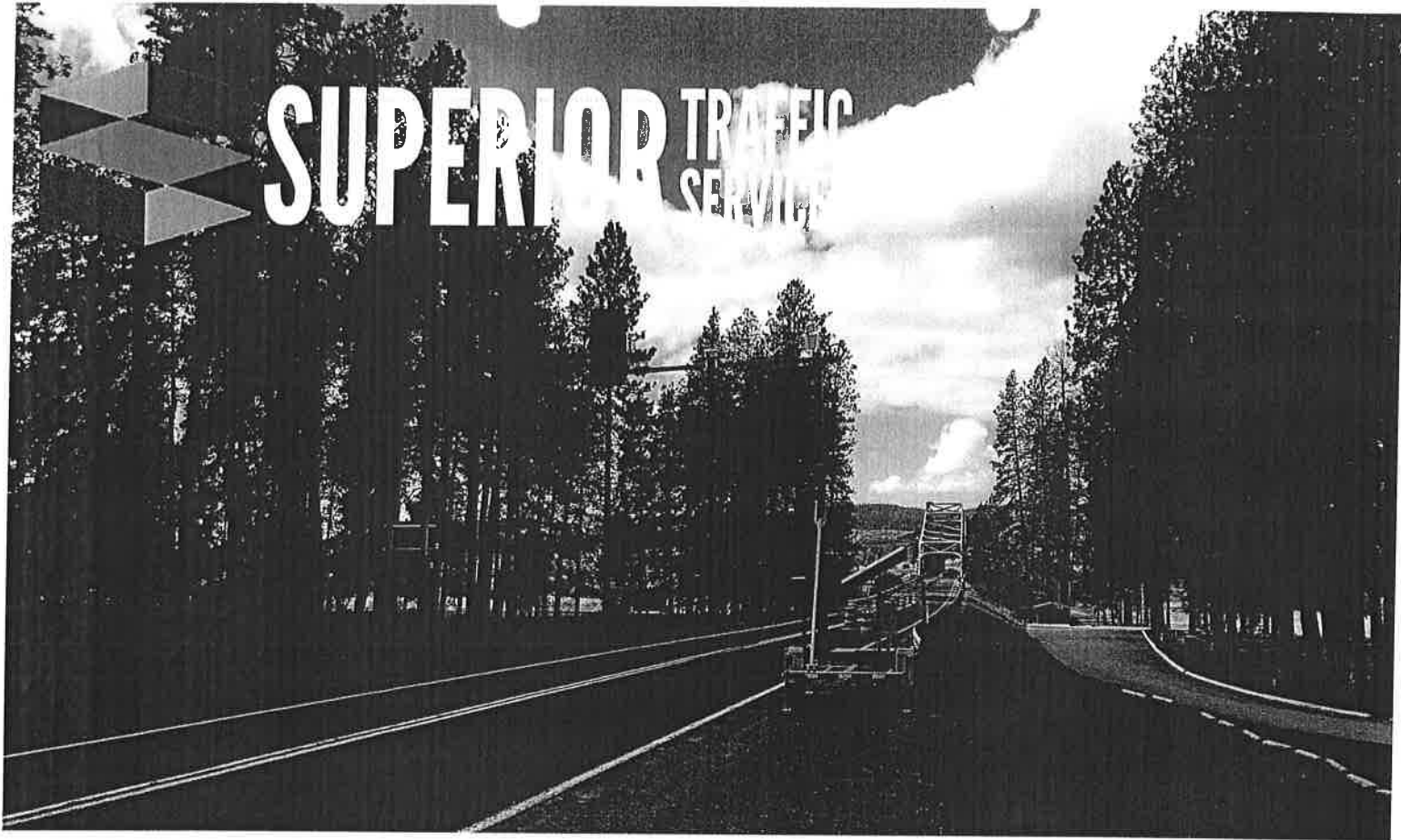

## STS PTS-1000A PORTABLE TRAFFIC SIGNAL

Superior Traffic Services set the new standard for intelligent Portable Traffic Signal Control systems through the development of its revolutionary patented Real-Time Traffic Management System (RTTMS) and STS LTC Controller.

**THE NEW ERA  
OF TRAFFIC  
CONTROL**

**TECHNOLOGY  
AND INNOVATION  
THAT WILL  
STOP TRAFFIC**

The STS PTS-1000A is the smart choice for safe and efficient temporary traffic control in a wide variety of short and long term applications. From complex intersections to simple lane closures, the STS PTS-1000A gets the job done.

Each STS PTS-1000A comes equipped with the STS LTC Controller and standard issue redundant radar & video vehicle detection, dual traffic and work zone facing web cameras, and triple redundant wireless communication.

These standard features, when coupled with the STS Real-Time Traffic Management System, and other optional features, make 24/7 Real-Time Configuration, Programming, Monitoring, and Control of signal systems simple.

[www.superiortrafficservices.com](http://www.superiortrafficservices.com)

1.406.552.1144

[info@superiortrafficservices.com](mailto:info@superiortrafficservices.com)

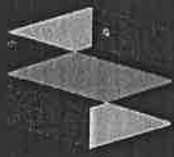

**SUPERIOR** TRAFFIC  
SERVICES

# STS PTS-1000A PORTABLE TRAFFIC SIGNAL

## STS PTS-1000A SPECS

- 180° Rotation ITE Polycarbonate Signal Heads
- 12" Diameter LEDs w/ Work Zone Safety Lights
- 17' Top Signal Clearance, 14' Bottom Signal Clearance
- 9' Mast Arm Reach from Side of Trailer
- 12v w/ 800 Ahr AGM Battery System
- 21 Day Autonomy based on Configuration
- 300 Watt Adjustable Photovoltaic Solar Array
- Electric over Hydraulic Deployment Lift Actuator
- 4 Leveling and Stabilizing Outriggers
- 2700 lb. +/- Trailer Weight, Narrow 72"W x 112"L
- 2-5/16" Ball Tandem Towable, 28'L Tandem Length

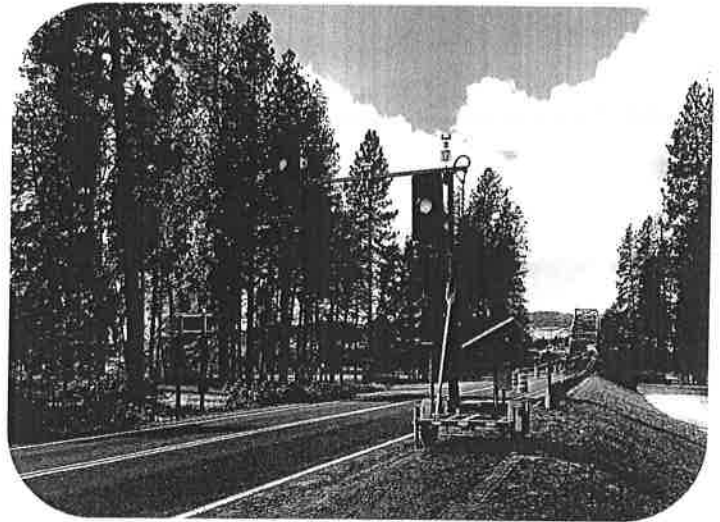

## OPTIONAL FEATURES & EQUIPMENT

- STS Level II Monitoring & Control
- Video, Radar, RFID and/or Presence Sensing Detection
- Emergency & Railroad Preemption
- Bicycle and Workzone Clearance Time Extender
- Countdown Timer and/or Changeable Message Board

## STS LTC CONTROLLER SPECS

- Remote Webpage Programming Interface
- Onboard Operation and System Status Display
- Interchangeable Master/Slave Designations
- Triple Redundant Wireless Communication Systems -900 MHz Radio, 2.4 GHz WiFi, and 4G Cellular
- Programmable Remote Control (1/2 Mile + Range)
- STS Network Watcher Conflict Monitoring
- Pager Alerts to Designated Stakeholders
- Unlimited System Fault and Status Log Storage
- Redundant Video and Radar Vehicle Detection
- Dual Traffic and Work Zone Facing Web Cams
- Live Real-Time Video Feeds with Playback
- Self-Contained with -30° to 135° Operation
- NEMA 4, 4X, & 6 Rated Lockable Enclosure



**NATIONWIDE DELIVERY WITH 24 / 7 LIVE REMOTE MONITORING**

[www.superiortrafficservices.com](http://www.superiortrafficservices.com)

1.406.552.1144

[info@superiortrafficservices.com](mailto:info@superiortrafficservices.com)



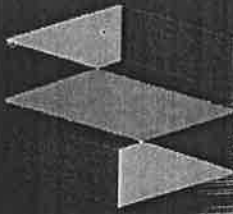

# SUPERIOR TRAFFIC SERVICES

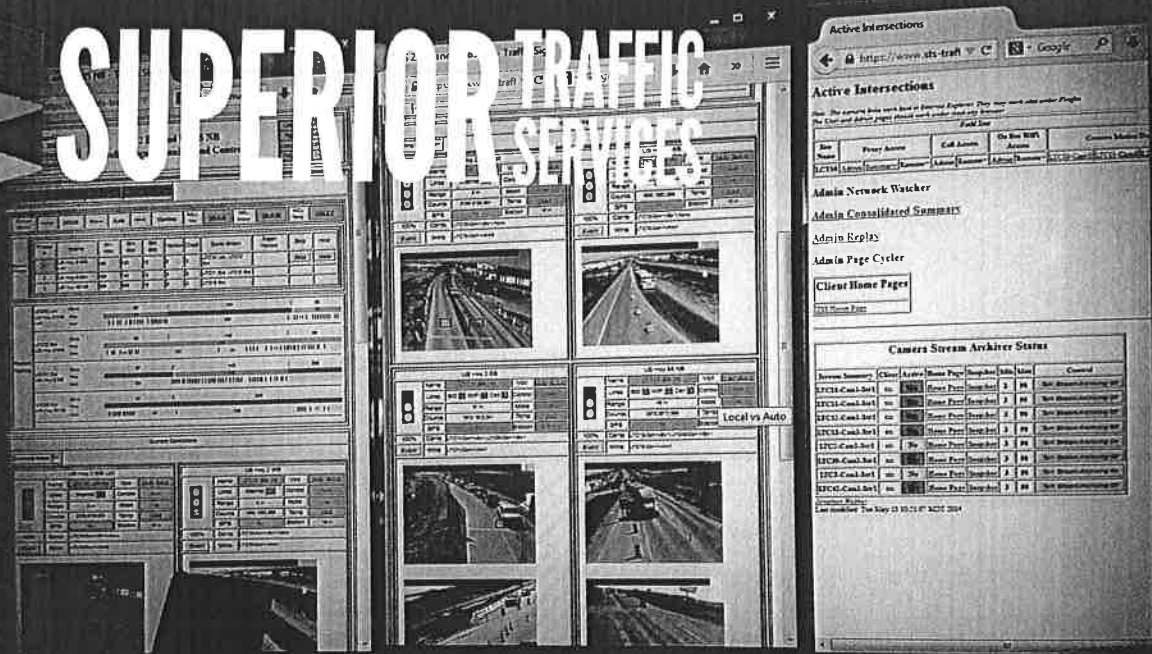

## REAL-TIME TRAFFIC MANAGEMENT SYSTEM

Superior Traffic Services set the new standard for intelligent Portable Traffic Signal Control systems through the development of its revolutionary, patented intelligent Real-Time Traffic Management System and STS LTC Controller.

**24/7 REAL-TIME  
TRAFFIC  
MANAGEMENT AT  
YOUR FINGERTIPS**

The STS Real-Time Traffic Management System (RTTMS) is the only Portable Traffic Signal Management Software that allows you to Program, Monitor, and Control your Temporary Portable Traffic Signals in Real-Time from anywhere with an internet enabled device. From the simple single lane closure to the most complex multi-phase intersections, the RTTMS makes work easy for everyone.

**INNOVATIVE  
TECHNOLOGY THAT  
MAKES THE TOUGHEST JOBS  
MANAGEABLE**

All STS Signal Systems come equipped with the STS LTC Controller and standard issue redundant radar & video detection, dual web cameras, and triple redundant wireless communication. With the RTTMS, these standard features make 24/7 Real-Time Configuration, Programming, System Status Monitoring, and Live Viewing of Traffic and Work Zones a walk in the park.

[www.superiortrafficservices.com](http://www.superiortrafficservices.com)

1.406.552.1144

[info@superiortrafficservices.com](mailto:info@superiortrafficservices.com)

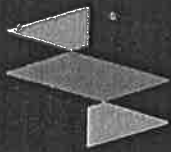

# SUPERIOR TRAFFIC SERVICES

# REAL-TIME TRAFFIC MANAGEMENT SYSTEM

## WITH LIVE WEB INTERFACE

System Status	Name	LTC228	Status	Auto	Sched	No	Mode	Cycling	MCU Volt	12.2 V	MCU Watts	14.3 W	MCU Temp	113.0 F					
Current Profile: Sequencing Signals	Phase #	Name	Grn Max	Grn Min	Grn Idle	Yellow	Clear	Ped Flash	Adv Flash	Solid Green	DMU	Flash Left	Ped Head	Auto-Ped	Adv Flash	SBI	Skip	Hold	Jump
	1	SB US-05	240	30	12	2	55	0	0	LTC107 Std							Skip	Hold	Jump
	2	NB US-05	240	30	12	2	55	0	0	LTC228 Std									Jump

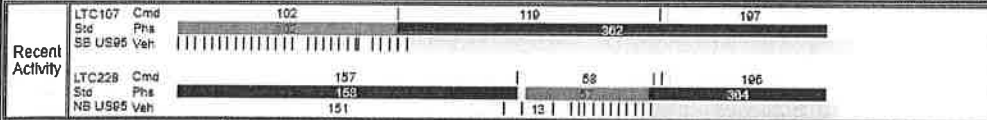

Dimming	Mode	AutoUpdate	Low Power	31%	Full Power	40%	Dim Before	05:52:22	Dim After	19:49:37	Currently Dimming?	No
---------	------	------------	-----------	-----	------------	-----	------------	----------	-----------	----------	--------------------	----

SB US95	Name	LTC107 (E)			
	Volt	12.3V	12.2V		
	Links	900 MHz WiFi 100 Cell 84			
	Temp	123.5 F	123.5 F	123.5 F	
	Power	Cam1	Cam2	Fan	
	Counts	Std:	131069	8347	495
	GPS	Fix: DGP Unknown MCU Range: 0 m			
	Speed	Cur: 7 MPH, Thresh: 5 MPH Radar Sensitivity: 50%, Lockout: 3			
	Event	OK			

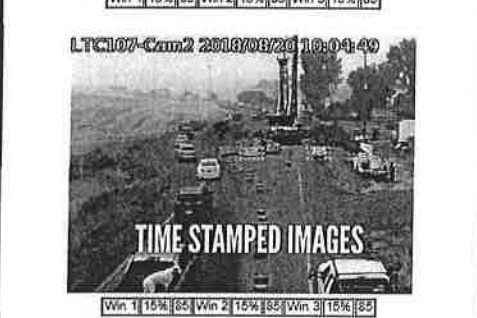

NB US95	Name	LTC228 (E)			
	Volt	12.2V	12.2V		
	Links	Internal 100			
	Temp	123.5 F	123.5 F	123.5 F	
	Power	Cam1	Cam2	Fan	
	Counts	Std:	114947	6264	200
	GPS	Fix: DGP Unknown MCU Range: 0 m			
	Speed	Cur: 0 MPH, Thresh: 5 MPH Radar Sensitivity: 99%, Lockout: 3			
	Event	OK			



## SYSTEM & PHASE DISPLAYS

- Displays RYG Phase and Cycle Values
- Displays Vehicle Demands, Counts, and Gaps
- Displays Current and Historical Cycle Times
- Displays GPS Location Map with Compass
- Displays LTC Systems Status and Temperature
- Displays Current Battery Voltage and History
- All Data is Archived and Available for Replay

## REDUNDANCY MEANS RELIABILITY

Each LTC Controller contains 3 radios, 900 Mhz radio, 2.4 Ghz WiFi, and Cellular. The LTCs communicate with each other over the strongest of the radio links. With 3 redundant options, you can be sure your signals are communicating reliably.

## LIVE CLIENT ACCESS

Each Client and Project Stakeholder are given login access to our RTTMS Dashboard Web Interface. You'll be able to view the same displays our control center is monitoring in Real-Time, including Live time-stamped video images of both traffic and the Work-Zone.

## STS CONTROL CENTER



The STS Control Center is staffed 24/7/365 by ATSSA Certified Flaggers to continuously monitor the RTTMS Traffic Programs, LTC Controller Systems, and Traffic Management of ongoing construction projects. **Level 1 Monitoring** includes broad level systematic monitoring by our control center and is standard issue on all STS Signal Systems. **Level 2 Monitoring** includes dedicated staff members closely monitoring all systems and remotely managing traffic around the clock. The STS Network Watcher system continuously monitors all systems for early and instantaneous text/pager notification of system status faults or threshold violations. Let the STS Control Center be your next 24/7 Onsite TCS!

# 24/7 LIVE VIDEO MONITORING & CONTROL



# City of Chattanooga

Mayor Andy Berke

September 4, 2019

Lurone Jennings  
Administrator  
Department of Youth and Family Development  
501 West 12<sup>th</sup> Street  
Chattanooga, TN 37402

Subject: PO 552002 Blanket Contract Renewal – Floor Care Services – Youth and Family Development/ Head Start Centers

Dear Mr. Jennings:

Council approval is recommended to extend blanket contract 552002 for Floor Care Services for the Head Start Centers. This will be the first (1<sup>st</sup>) contract renewal for twelve (12) months with the option to renew for one (1) additional twelve (12) month term. The estimated annual expenditure for this contract is \$33,000.

The bid solicitation was sent to six (6) vendors and three (3) bids were received. Bids are available in the Purchasing Office for your review upon request. A copy of blanket contract 552002 is attached.

I recommend renewal of this contract to Alternative Source, P.O. Box 514 Ooltewah, TN 37363, for an additional year, as being in the best interest for the City of Chattanooga

Respectfully yours,

Bonnie Woodward  
Director of Purchasing

BW/js  
Attachments

# Purchase Order BLANKET



**City of Chattanooga**  
101 East 11th Street, Suite G13  
Chattanooga, TN 37402

<b>V E N D O R</b>	Vendor Number: Vendor Alternate ID: 22297  Alternative Source PO Box 514 Ooltewah, TN 37363
--	--

PO Date: 26-NOV-18 Buyer: William Tucker FOB: DESTINATION Terms: Immediate	<b>Purchase Order Number 552002</b>  INVOICES: Direct invoices in DUPLICATE to the Invoice address shown below.
---	---

<b>S H I P T O</b>	
--	--

<b>I N V O I C E</b>	Accounts Payable Division City of Chattanooga 101 East 11th Street, Suite 101 Chattanooga, TN 37402
--	--

Requestor		Requisition Number		Bid Number	
Line Nbr	Item ID - Item Description	Quantity	Unit	Unit Price	Total
Requisition No: 177301 Ordering Dept: Youth and Family Development Buyer: William Tucker Fax: 423-643-7244 Email: wtucker@chattanooga.gov *****					
This shall be a twelve-month blanket contract to supply Floor Care Services at Head Start Centers as needed by agencies of the City of Chattanooga. The contract terms may be renewed for two (2) additional twelve (12)-month terms under the same terms and conditions by mutual agreement. The City of Chattanooga and the Contractor may extend the contract by providing written confirmation of agreement by both parties at least 30 days prior to the contract's current expiration date. *****					
Vendor Contact Information:					
Vendor Name: Alternative Source Contact Person: Barry Gilbert Tel.: 423-280-5285 Fax: Email: brgilbert006@gmail.com Mailing Address: 4205 Dodds Avenue City, State, Zip: Chattanooga, TN *****					

\*\*\*\*\* NOTICE \*\*\*\*\*

This Purchase Order ("Agreement") is a binding agreement between the City of Chattanooga and the Vendor. This Purchase Order shall be governed by the following documents: (1) Purchase Order; (2) City of Chattanooga Purchase Order Standard Terms and Conditions; (3) Vendor's response to the bid or quotation, and (4) terms and conditions set forth in the bid or quotation, each of which is hereby incorporated herein by reference and becomes a part of this Agreement. In the event any conflict of terms arises, the terms controlling the Agreement shall be in the order provided hereinabove. This Purchase Order is valid only when signed or electronically approved by the Finance Officer.

Electronic approval is on record in the purchasing information system which asserts that unencumbered appropriation is available to meet the expenditure covered by this Purchase Order; and further authorizes payment upon proper certification of receipt of goods and/or services.

# Purchase Order BLANKET



**City of Chattanooga**  
101 East 11th Street, Suite G13  
Chattanooga, TN 37402

<b>V E N D O R</b>	Vendor Number: Vendor Alternate ID: 22297
	Alternative Source PO Box 514 Ooltewah, TN 37363

PO Date: 26-NOV-18 Buyer: William Tucker FOB: DESTINATION Terms: Immediate	Purchase Order Number <b>552002</b>  INVOICES: Direct invoices in DUPLICATE to the Invoice address shown below.
---	--

<b>S H I P T O</b>	
--	--

<b>I N V O I C E</b>	Accounts Payable Division City of Chattanooga 101 East 11th Street, Suite 101 Chattanooga, TN 37402
--	--

Requestor			Requisition Number		Bid Number
Line Nbr	Item ID - Item Description	Quantity	Unit	Unit Price	Total
1	Strip and wax all tile and solid surface floors in conjunction with the Shampooing of all Carpets and Rugs in Avondale Head Start	0.00	Each	\$ 8,580.0000	\$ 0.00
2	Strip and wax all tile and solid surface floors in conjunction with the Shampooing of all Carpets and Rugs in Avondale EHS Head Start	0.00	Each	\$ 1,650.0000	\$ 0.00
3	Strip and wax all tile and solid surface floors in conjunction with the Shampooing of all Carpets and Rugs in Daisy HS	0.00	Each	\$ 2,605.0000	\$ 0.00
4	Strip and wax all tile and solid surface floors in conjunction with the Shampooing of all Carpets and Rugs in Cedar Hill	0.00	Each	\$ 2,372.0000	\$ 0.00
5	Strip and wax all tile and solid surface floors in conjunction with the Shampooing of all Carpets and Rugs in North Chatt	0.00	Each	\$ 1,270.0000	\$ 0.00

**TOTAL: \$ .00**

\*\*\*\*\* NOTICE \*\*\*\*\*

This Purchase Order ("Agreement") is a binding agreement between the City of Chattanooga and the Vendor. This Purchase Order shall be governed by the following documents: (1) Purchase Order; (2) City of Chattanooga Purchase Order Standard Terms and Conditions; (3) Vendor's response to the bid or quotation, and (4) terms and conditions set forth in the bid or quotation, each of which is hereby incorporated herein by reference and becomes a part of this Agreement. In the event any conflict of terms arises, the terms controlling the Agreement shall be in the order provided hereinabove. This Purchase Order is valid only when signed or electronically approved by the Finance Officer.

Electronic approval is on record in the purchasing information system which asserts that unencumbered appropriation is available to meet the expenditure covered by this Purchase Order; and further authorizes payment upon proper certification of receipt of goods and/or services.



# City of Chattanooga

Mayor Andy Berke

September 17, 2019

Mr. Justin Holland  
Administrator, Public Works Department  
City Wide Services Division  
1250 Market Street, Suite 2100  
Chattanooga, TN 37402

Subject: Requisition No. 190064 – Purchase of One (1) Toro Groundsmaster 3505-D Mower & Two (2) Toro Workman GTX EFI Bucket Utility – Parks Division – Public Works Department

Dear Mr. Holland:

Council approval is recommended to issue a purchase order for the purchase of one (1) Toro Groundsmaster 3505-D Mower and two (2) Toro Workman GTX EFI Bucket Utility Vehicles as needed by the Parks Division of the Public Work Department.

This purchase is from Smith Turf & Irrigation using the State of Tennessee Contract No. SWC242-45200. The total cost will be \$48,195.00. TCA 6-56-304.6 allows for this single source purchase exempted from the usual advertising and bidding procedures.

I recommend approval of this purchase to Smith Turf & Irrigation, 525 Fairground Court, Nashville, TN 37211, as being in the best interest of the City of Chattanooga.

Respectfully yours,

Bonnie Woodward  
Director of Purchasing

BW/mlm

Attachments

# SMITH TURF & IRRIGATION

DISTRIBUTORS

**Quoted To:**  
City of Chattanooga, Public Works



**Quoted From:**  
Nashville Office  
525 Fairground Court  
Nashville, TN 37211  
615-726-8811

**Attn:**  
Jay Hawkins

**Territory Manager:** G. Timothy Long, SCPS

Qty	Model	Description	Unit Price	Extended
Tennessee Statewide Contract, 242				
1	30849	Groundsmaster 3505-D		\$29,374.40
1	44963	MVP Kit 1000 Hour		
2	07059	Workman GTX EFI Bucket	\$8,757.06	\$17,514.12
2	07921	2-Person Canopy	\$395.46	\$790.92
2	07923	Fold-Down Windshield	\$258.18	\$516.36
			<b>Total</b>	<b>\$48,195.80</b>

**Payment Terms:** Net 10th Prox (Upon Credit Approval)

Prices And Terms Shown Will Be Valid For 30 Days From Date Quoted.  
After This Period, We Reserve The Right To Make Any Necessary  
Adjustments To Prices And/Or Payment Terms.

**Sub Total** \$48,195.80

**\*Sales Tax**

**Total**

**Quote Prepared By:** G. Timothy Long

**Date:** 8/23/2019

**Quote Accepted By:** \_\_\_\_\_

**Date:** \_\_\_\_\_

\* Sales Tax is subject to change based on the current rules and regulations in effect at the time of delivery



STATE OF TENNESSEE, DEPARTMENT OF GENERAL SERVICES  
CENTRAL PROCUREMENT OFFICE

Statewide Contract Issued to:

Smith Turf And Irrigation  
PO Box 669388

Charlotte, NC 28266-9388

Vendor ID: 0000046950

**Contract Number: 000000000000000000045200**

Title: SWC 242 Ground Maint Equip

Start Date : March 16, 2015 End Date: March 15, 2020

Is this contract available to local government agencies in addition to State agencies?: Yes

**Authorized Users.** This Contract establishes a source or sources of supply for all Tennessee State Agencies. "Tennessee State Agency" refers to the various departments, institutions, boards, commissions, and agencies of the executive branch of government of the State of Tennessee with exceptions as addressed in Tenn. Comp. R. & Regs. 0690-03-01-.01. The Contractor shall provide all goods or services and deliverables as required by this Contract to all Tennessee State Agencies. The Contractor shall make this Contract available to the following entities, who are authorized to and who may purchase off of this Statewide Contract ("Authorized Users"):

- a. all Tennessee State governmental entities (this includes the legislative branch; judicial branch; and, commissions and boards of the State outside of the executive branch of government);
- b. Tennessee local governmental agencies;
- c. members of the University of Tennessee or Tennessee Board of Regents systems;
- d. any private nonprofit institution of higher education chartered in Tennessee; and,
- e. any corporation which is exempted from taxation under 26 U.S.C. Section 501(c)(3), as amended, and which contracts with the Department of Mental Health and Substance Abuse to provide services to the public (Tenn. Code Ann. § 33-2-1001).

These Authorized Users may utilize this Contract by purchasing directly from the Contractor according to their own procurement policies and procedures. The State is not responsible or



liable for the transactions between the Contractor and Authorized Users.

Note: If "no", attach exemption request addressed to the Central Procurement Officer.

**Contract Contact Information:**

State of Tennessee  
Department of General Services, Central Procurement Office  
Contract Administrator: Lindsey Lattner  
3rd Floor, William R Snodgrass, Tennessee Tower  
312 Rosa L. Parks Avenue  
Nashville, TN 37243-1102  
Phone: 615-741-9282  
Fax: 615-741-0684  
Email: [Lindsey.Lattner@tn.gov](mailto:Lindsey.Lattner@tn.gov)

Line Information

**Line 1**

Item ID:

*1000168598 Ground Maintenance Equipment UTV's Utility Vehicles*

Unit of Measure: EA

Vendor Item/Part #:

Manufacturer Item #:

Unit Price: \$ 0

**Line 2**

Item ID:

*1000168599 Ground Maintenance Equipment UTV's Utility Vehicle Options*

Unit of Measure: EA

Vendor Item/Part #:

Manufacturer Item #:

Unit Price: \$ 0

**Line 3**

Item ID:

*1000168605 Ground Maintenance Equipment Commercial Front and Wide Area Mowers*

Unit of Measure: EA

Vendor Item/Part #:

Manufacturer Item #:

Unit Price: \$ 0

**Line 4**

Item ID:

*1000168606 Ground Maintenance Equipment Golf Course Mowerw, Gand Ground Maintenance*

Unit of Measure: EA

Vendor Item/Part #:

Manufacturer Item #:

Unit Price: \$ 0

**Line 5**

Item ID:

*1000168602 Ground Maintenance Equipment Manufacturer Accessories and Optional Equipment (Does not include replacement repair parts)*

Unit of Measure: EA

Vendor Item/Part #:

Manufacturer Item #:

Unit Price: \$ 0

**Line 6**

Item ID:

*1000168607 Ground Maintenance Equipment Aerators, Plugger, and Spikers*

Unit of Measure: EA  
Vendor Item/Part #:  
Manufacturer Item #:  
Unit Price: \$ 0

**Line 7**

Item ID:  
*1000168608 Ground Maintenance Equipment Spreaders, Broadcast, Fertilizer and Seed*  
Unit of Measure: EA  
Vendor Item/Part #:  
Manufacturer Item #:  
Unit Price: \$ 0

**Line 8**

Item ID:  
*1000168609 Ground Maintenance Equipment Rakers and Combers, Lawn Power*  
Unit of Measure: EA  
Vendor Item/Part #:  
Manufacturer Item #:  
Unit Price: \$ 0

**Line 9**

Item ID:  
*1000168610 Ground Maintenance Equipment Roller, Lawn*  
Unit of Measure: EA  
Vendor Item/Part #:  
Manufacturer Item #:  
Unit Price: \$ 0

Michael F.

Perry/AWB

APPROVED:

CHIEF PROCUREMENT OFFICER

Digitally signed by Michael F. Perry/  
AWB  
DN: cn=Michael F. Perry/AWB,  
o=Central Procurement Office, ou,  
email=Tony.Bybee@us.pps.c=US  
Date: 2019.01.18 07:20:48 -0600

BY:

*Devon Wallace*

PURCHASING AGENT

1/17/2019

DATE



# City of Chattanooga

Mayor Andy Berke

September 17, 2019

Mr. Justin Holland  
Administrator, Public Works Department  
Parks Division  
1250 Market Street, Suite 2100  
Chattanooga, TN 37402

**Subject: Contract Renewal of Blanket PO No. 551958 – Youth Athletic Association  
Baseball Field Renovations – Parks Division – Public Works Department**

Dear Mr. Holland:

Council approval is recommended to renew Blanket PO No. 551958 for Youth Athletic Association Baseball Field Renovations, Parks Division, Public Works Department. The City of Chattanooga is renewing the first (1<sup>st</sup>) contract renewal option for twelve (12) months, with one (1) renewal option remaining for an estimated annual amount of \$115,000. A copy of the contract is enclosed.

The original invitation to bid was sent to fourteen (14) vendors as well as formally advertised. Bids were received from two (2) vendors. Bid is retained on file in the Purchasing Office for your review upon request.

I recommend renewing Blanket PO No. 551958 for Youth Athletic Association Baseball Field Renovations to River City Athletic Fields, P.O. Box 685, Soddy Daisy, TN 37379.

Respectfully yours,

Bonnie Woodward  
Director of Purchasing

BW/mlm

Attachments

# Purchase Order BLANKET



**City of Chattanooga**  
101 East 11th Street, Suite G13  
Chattanooga, TN 37402

<b>V E N D O R</b>	Vendor Number: Vendor Alternate ID: 22872  River City Athletic Fields PO Box 685 Soddy Daisy, TN 37379
--	---

PO Date: 19-NOV-18 Buyer: Mark McKeel FOB: DESTINATION Terms: Immediate	<b>Purchase Order Number 551958</b>  INVOICES: Direct invoices in DUPLICATE to the Invoice address shown below.
--	---

<b>S H I P T O</b>	
--	--

<b>I N V O I C E</b>	Accounts Payable Division City of Chattanooga 101 East 11th Street, Suite 101 Chattanooga, TN 37402
--	--

Requestor		Requisition Number		Bid Number	
<b>Line Nbr</b>	<b>Item ID - Item Description</b>	<b>Quantity</b>	<b>Unit</b>	<b>Unit Price</b>	<b>Total</b>
Requisition / Bid No.: 176621 / 305250 Ordering Dept.: Parks Division, Public Works Department Buyer: Mark McKeel Phone No.: 423-643-7236  Items Being Purchased: Youth Athletic Association Baseball Field Renovations  ATTACHMENTS: City of Chattanooga (COC) Terms and Conditions posted on Website <a href="http://www.chattanooga.gov/purchasing/standard-terms-and-conditions">http://www.chattanooga.gov/purchasing/standard-terms-and-conditions</a> If you can't download call buyer for a copy.  This Shall Be A Twelve (12) Month Blanket Contract To Supply Renovation Services for Youth Athletic Association Baseball Fields for Parks Division.  The Contract Term May Be Renewed For An Additional Two (2) Twelve (12) Month Terms Under The Same Terms And Conditions By Mutual Agreement. The City Of Chattanooga And The Contractor May Bilaterally Extend The Contract By Providing Written Confirmation Of Agreement By Both Parties At Least 30 Days Prior To The Contract's Current Expiration Date Into Any Successive Term As Provided Herein.  ***** Vendor Shall Hold Prices Firm for First (1st) Year of Contract *****  Price Escalation Clause: If as a result of a general change in prices or discounts, the Contractor has changed prices to all of its customers, the price under this contract may be adjusted accordingly. Contractor may be requested to show proof of alleged price changes prior to approval of any price adjustments.					

\*\*\*\*\* NOTICE \*\*\*\*\*

This Purchase Order ("Agreement") is a binding agreement between the City of Chattanooga and the Vendor. This Purchase Order shall be governed by the following documents: (1) Purchase Order; (2) City of Chattanooga Purchase Order Standard Terms and Conditions; (3) Vendor's response to the bid or quotation; and (4) terms and conditions set forth in the bid or quotation, each of which is hereby incorporated herein by reference and becomes a part of this Agreement. In the event any conflict of terms arises, the terms controlling the Agreement shall be in the order provided hereinabove. This Purchase Order is valid only when signed or electronically approved by the Finance Officer.

Electronic approval is on record in the purchasing information system which asserts that unencumbered appropriation is available to meet the expenditure covered by this Purchase Order; and further authorizes payment upon proper certification of receipt of goods and/or services.

# Purchase Order BLANKET



**City of Chattanooga**  
101 East 11th Street, Suite G13  
Chattanooga, TN 37402

<b>V E N D O R</b>	Vendor Number: Vendor Alternate ID: 22872
	River City Athletic Fields PO Box 685 Soddy Daisy, TN 37379

PO Date: 19-NOV-18 Buyer: Mark McKeel FOB: DESTINATION Terms: Immediate	<b>Purchase Order Number 551958</b>  INVOICES: Direct invoices in DUPLICATE to the Invoice address shown below.
--	---

<b>S H I P T O</b>	
--	--

<b>I N V O I C E</b>	Accounts Payable Division City of Chattanooga 101 East 11th Street, Suite 101 Chattanooga, TN 37402
--	--

Requestor		Requisition Number		Bid Number	
<b>Line Nbr</b>	<b>Item ID - Item Description</b>	<b>Quantity</b>	<b>Unit</b>	<b>Unit Price</b>	<b>Total</b>
QUANTITIES ARE ESTIMATES ONLY THE CITY OF CHATTANOOGA SHALL GUARANTEE NO MINIMUM OR MAXIIMUM AMOUNT PURCHASED DURING THE LIFETIME OF THE CONTRACT.					
Puirchase Order issued in accordance with River City Athletic Fields bid recieved on October 30, 2018 is hereby made part of this contract.					
City Council approved on November 13, 2018					
Contract dates: November 20, 2018 to November 19, 2019					
Vendor Contact: Alex Vaughn Phone No.: 423-580-1431 E-mail: alex@rivercityathleticfields.com					
The undersigned hereby agrees to perform the services in accordance with the terms and conditions as set forth in this Purchase Order, the City of Chattanooga Standard Terms & Conditions, and the bid or quotation.					
Representative: _____		Agreed to and accepted by: _____			
Title: _____		CITY OF CHATTANOOGA, TENNESSEE			
Date: _____		Name/Title: _____		Department: _____	

\*\*\*\*\* NOTICE \*\*\*\*\*

This Purchase Order ("Agreement") is a binding agreement between the City of Chattanooga and the Vendor. This Purchase Order shall be governed by the following documents: (1) Purchase Order; (2) City of Chattanooga Purchase Order Standard Terms and Conditions; (3) Vendor's response to the bid or quotation; and (4) terms and conditions set forth in the bid or quotation, each of which is hereby incorporated herein by reference and becomes a part of this Agreement. In the event any conflict of terms arises, the terms controlling the Agreement shall be in the order provided hereinabove. This Purchase Order is valid only when signed or electronically approved by the Finance Officer.

Electronic approval is on record in the purchasing information system which asserts that unencumbered appropriation is available to meet the expenditure covered by this Purchase Order; and further authorizes payment upon proper certification of receipt of goods and/or services.

# Purchase Order BLANKET



**City of Chattanooga**  
101 East 11th Street, Suite G13  
Chattanooga, TN 37402

<b>V E N D O R</b>	Vendor Number: Vendor Alternate ID: 22872
	River City Athletic Fields PO Box 685 Soddy Daisy, TN 37379

PO Date: 19-NOV-18 Buyer: Mark McKeel FOB: DESTINATION Terms: Immediate	<b>Purchase Order Number 551958</b>  INVOICES: Direct invoices in DUPLICATE to the Invoice address shown below.
--	---

<b>S H I P T O</b>	
--	--

<b>I N V O I C E</b>	Accounts Payable Division City of Chattanooga 101 East 11th Street, Suite 101 Chattanooga, TN 37402
--	--

Requestor		Requisition Number			Bid Number
Line Nbr	Item ID - Item Description	Quantity	Unit	Unit Price	Total
1	Hixson Field 1 Renovation	0.00	Job	\$ 5,200.0000	\$ 0.00
3	Hixson Field 2 Renovation	0.00	Job	\$ 5,200.0000	\$ 0.00
4	Hixson Field 3 Renovation	0.00	Job	\$ 3,450.0000	\$ 0.00
5	Hixson Field 4 Renovation	0.00	Job	\$ 4,650.0000	\$ 0.00
6	Hixson Field 5 Renovation	0.00	Job	\$ 4,650.0000	\$ 0.00
7	Hixson Field 6 Renovation	0.00	Job	\$ 3,450.0000	\$ 0.00
8	Hixson Field 7 Renovation	0.00	Job	\$ 6,350.0000	\$ 0.00
9	Hixson Field 8 Renovation	0.00	Job	\$ 5,850.0000	\$ 0.00
10	Rivermont Field 1 Renovation	0.00	Job	\$ 2,250.0000	\$ 0.00
11	Rivermont Field 2 Renovation	0.00	Job	\$ 2,250.0000	\$ 0.00

\*\*\*\*\* NOTICE \*\*\*\*\*

This Purchase Order ("Agreement") is a binding agreement between the City of Chattanooga and the Vendor. This Purchase Order shall be governed by the following documents: (1) Purchase Order; (2) City of Chattanooga Purchase Order Standard Terms and Conditions; (3) Vendor's response to the bid or quotation; and (4) terms and conditions set forth in the bid or quotation, each of which is hereby incorporated herein by reference and becomes a part of this Agreement. In the event any conflict of terms arises, the terms controlling the Agreement shall be in the order provided hereinabove. This Purchase Order is valid only when signed or electronically approved by the Finance Officer.

Electronic approval is on record in the purchasing information system which asserts that unencumbered appropriation is available to meet the expenditure covered by this Purchase Order, and further authorizes payment upon proper certification of receipt of goods and/or services.

# Purchase Order

## BLANKET



**City of Chattanooga**  
101 East 11th Street, Suite G13  
Chattanooga, TN 37402

<b>V E N D O R</b>	Vendor Number: Vendor Alternate ID: 22872  River City Athletic Fields PO Box 685 Soddy Daisy, TN 37379
--	---

PO Date: 19-NOV-18 Buyer: Mark McKeel FOB: DESTINATION Terms: Immediate	<b>Purchase Order Number</b> <b>551958</b>  INVOICES: Direct invoices in DUPLICATE to the Invoice address shown below.
--	---

<b>S H I P T O</b>	
--	--

<b>I N V O I C E</b>	Accounts Payable Division City of Chattanooga 101 East 11th Street, Suite 101 Chattanooga, TN 37402
--	--

Requestor			Requisition Number		Bid Number
Line Nbr	Item ID - Item Description	Quantity	Unit	Unit Price	Total
12	Rivermont Field 3 Renovation	0.00	Job	\$ 2,250.0000	\$ 0.00
13	Rivermont Field 4 (Option A) Renovation	0.00	Job	\$ 7,300.0000	\$ 0.00
14	Rivermont Field 4 (Option B) Renovation	0.00	Job	\$ 14,350.0000	\$ 0.00
15	Rivermont Field 5 Renovation	0.00	Job	\$ 2,250.0000	\$ 0.00
16	Rivermont Field 6 Renovation	0.00	Job	\$ 2,250.0000	\$ 0.00
17	Rivermont Field 7 Renovation	0.00	Job	\$ 2,250.0000	\$ 0.00
18	Lookout Valley Field 1 Renovation	0.00	Job	\$ 4,400.0000	\$ 0.00
19	Lookout Valley Field 2 Renovation	0.00	Job	\$ 4,650.0000	\$ 0.00
20	Lookout Valley Field 3 Renovation	0.00	Job	\$ 3,450.0000	\$ 0.00
21	Lookout Valley Field 4 Renovation	0.00	Job	\$ 4,650.0000	\$ 0.00

\*\*\*\*\* NOTICE \*\*\*\*\*

This Purchase Order ("Agreement") is a binding agreement between the City of Chattanooga and the Vendor. This Purchase Order shall be governed by the following documents: (1) Purchase Order; (2) City of Chattanooga Purchase Order Standard Terms and Conditions; (3) Vendor's response to the bid or quotation; and (4) terms and conditions set forth in the bid or quotation, each of which is hereby incorporated herein by reference and becomes a part of this Agreement. In the event any conflict of terms arises, the terms controlling the Agreement shall be in the order provided hereinabove. This Purchase Order is valid only when signed or electronically approved by the Finance Officer.

Electronic approval is on record in the purchasing information system which asserts that unencumbered appropriation is available to meet the expenditure covered by this Purchase Order; and further authorizes payment upon proper certification of receipt of goods and/or services.

# Purchase Order BLANKET



**City of Chattanooga**  
101 East 11th Street, Suite G13  
Chattanooga, TN 37402

<b>V E N D O R</b>	Vendor Number: Vendor Alternate ID: 22872
	River City Athletic Fields PO Box 685 Soddy Daisy, TN 37379

PO Date: 19-NOV-18 Buyer: Mark McKeel FOB: DESTINATION Terms: Immediate	<b>Purchase Order Number</b> <b>551958</b>
<b>INVOICES: Direct invoices in DUPLICATE to the Invoice address shown below.</b>	

<b>S H I P T O</b>	
--	--

<b>I N V O I C E</b>	Accounts Payable Division City of Chattanooga 101 East 11th Street, Suite 101 Chattanooga, TN 37402
--	--

Requestor			Requisition Number		Bid Number
Line Nbr	Item ID - Item Description	Quantity	Unit	Unit Price	Total
22	Lookout Valley Field 5 Renovation	0.00	Job	\$ 3,450.0000	\$ 0.00
23	Lakeside Field 1 Renovation	0.00	Job	\$ 3,450.0000	\$ 0.00
24	Lakeside Field 2 Renovation	0.00	Job	\$ 3,450.0000	\$ 0.00
25	Lakeside Field 3 Renovation	0.00	Job	\$ 3,450.0000	\$ 0.00
26	Lakeside Field 4 Renovation	0.00	Job	\$ 3,450.0000	\$ 0.00
27	Lakeside Field 5 Renovation	0.00	Job	\$ 3,450.0000	\$ 0.00

**TOTAL: \$ .00**

\*\*\*\*\* NOTICE \*\*\*\*\*

This Purchase Order ("Agreement") is a binding agreement between the City of Chattanooga and the Vendor. This Purchase Order shall be governed by the following documents: (1) Purchase Order; (2) City of Chattanooga Purchase Order Standard Terms and Conditions; (3) Vendor's response to the bid or quotation; and (4) terms and conditions set forth in the bid or quotation, each of which is hereby incorporated herein by reference and becomes a part of this Agreement. In the event any conflict of terms arises, the terms controlling the Agreement shall be in the order provided hereinabove. This Purchase Order is valid only when signed or electronically approved by the Finance Officer.

Electronic approval is on record in the purchasing information system which asserts that unencumbered appropriation is available to meet the expenditure covered by this Purchase Order; and further authorizes payment upon proper certification of receipt of goods and/or services.





# City of Chattanooga

Mayor Andy Berke

September 17, 2019

Mr. Justin Holland  
Administrator, Public Works Department  
Parks Division  
1250 Market Street, Suite 2100  
Chattanooga, TN 37402

**Subject: Contract Renewal of Blanket PO No. 552038 – Playground Inspection Services  
– Parks Division – Public Works Department**

Dear Mr. Holland:

Council approval is recommended to renew Blanket PO No. 552038 for Playground Inspection Services, Parks Division, Public Works Department. The City of Chattanooga is renewing the first (1<sup>st</sup>) contract renewal option for twelve (12) months, with one (1) renewal option remaining for an estimated annual amount of \$45,000. A copy of the contract is enclosed.

The original invitation to bid was sent to nine (9) vendors as well as formally advertised. Bids were received from two (2) vendors. Bid is retained on file in the Purchasing Office for your review upon request.

I recommend renewing Blanket PO No. 552038 for Playground Inspection Services to Playground Guardian, LLC, P.O. Box 240981, Charlotte, NC 28224.

Respectfully yours,

Bonnie Woodward  
Director of Purchasing

BW/mlm

Attachments

# Purchase Order BLANKET



**City of Chattanooga**  
101 East 11th Street, Suite G13  
Chattanooga, TN 37402

<b>V E N D O R</b>	Vendor Number: Vendor Alternate ID: 986245  Playground Guardian LLC PO Box 240981 Charlotte, NC 28224
--	--

PO Date: 28-NOV-18 Buyer: Mark McKeel FOB: DESTINATION Terms: Immediate
--

<b>Purchase Order Number 552038</b>
INVOICES: Direct invoices in DUPLICATE to the Invoice address shown below.

<b>S H I P T O</b>	
--	--

<b>I N V O I C E</b>	Accounts Payable Division City of Chattanooga 101 East 11th Street, Suite 101 Chattanooga, TN 37402
--	--

Requestor			Requisition Number		Bid Number
<b>Line Nbr</b>	<b>Item ID - Item Description</b>	<b>Quantity</b>	<b>Unit</b>	<b>Unit Price</b>	<b>Total</b>
Requisition / Bid No.: 176632 / 305251 Ordering Dept.: Parks Division, Public Works Department Buyer: Mark McKeel Phone No.: 423-643-7236  Items Being Purchased: Playground Inspection Services  ATTACHMENTS: City of Chattanooga (COC) Terms and Conditions posted on Website <a href="http://www.chattanooga.gov/purchasing/standard-terms-and-conditions">http://www.chattanooga.gov/purchasing/standard-terms-and-conditions</a> If you can't download call buyer for a copy.  This Shall Be A Twelve (12) Month Blanket Contract To Supply Playground Inspection Services for Parks Division.  The Contract Term May Be Renewed For An Additional Two (2) Twelve (12) Month Terms Under The Same Terms And Conditions By Mutual Agreement. The City Of Chattanooga And The Contractor May Bilaterally Extend The Contract By Providing Written Confirmation Of Agreement By Both Parties At Least 30 Days Prior To The Contract's Current Expiration Date Into Any Successive Term As Provided Herein.  **** Vendor Shall Hold Prices Firm for First (1st) Year of Contract ****  Price Escalation Clause: If as a result of a general change in prices or discounts, the Contractor has changed prices to all of its customers, the price under this contract may be adjusted accordingly. Contractor may be requested to show proof of alleged price changes prior to approval of any price adjustments.					

\*\*\*\*\* NOTICE \*\*\*\*\*

This Purchase Order ("Agreement") is a binding agreement between the City of Chattanooga and the Vendor. This Purchase Order shall be governed by the following documents: (1) Purchase Order; (2) City of Chattanooga Purchase Order Standard Terms and Conditions; (3) Vendor's response to the bid or quotation; and (4) terms and conditions set forth in the bid or quotation, each of which is hereby incorporated herein by reference and becomes a part of this Agreement. In the event any conflict of terms arises, the terms controlling the Agreement shall be in the order provided hereinabove. This Purchase Order is valid only when signed or electronically approved by the Finance Officer.

Electronic approval is on record in the purchasing information system which asserts that unencumbered appropriation is available to meet the expenditure covered by this Purchase Order, and further authorizes payment upon proper certification of receipt of goods and/or services.

# Purchase Order BLANKET



**City of Chattanooga**  
101 East 11th Street, Suite G13  
Chattanooga, TN 37402

<b>V E N D O R</b>	Vendor Number: Vendor Alternate ID: 986245  Playground Guardian LLC PO Box 240981 Charlotte, NC 28224
--	--

PO Date: 28-NOV-18 Buyer: Mark McKeel FOB: DESTINATION Terms: Immediate	<b>Purchase Order Number 552038</b>  INVOICES: Direct invoices in DUPLICATE to the Invoice address shown below.
--	---

<b>S H I P T O</b>	
--	--

<b>I N V O I C E</b>	Accounts Payable Division City of Chattanooga 101 East 11th Street, Suite 101 Chattanooga, TN 37402
--	--

Requestor	Requisition Number	Bid Number						
<table border="1" style="width: 100%; border-collapse: collapse;"> <thead> <tr> <th style="width: 10%;">Line Nbr</th> <th style="width: 70%;">Item ID - Item Description</th> <th style="width: 10%;">Quantity</th> <th style="width: 5%;">Unit</th> <th style="width: 5%;">Unit Price</th> <th style="width: 10%;">Total</th> </tr> </thead> </table> <p>QUANTITIES ARE ESTIMATES ONLY THE CITY OF CHATTANOOGA SHALL GUARANTEE NO MINIMUM OR MAXIMUM AMOUNT PURCHASED DURING THE LIFETIME OF THE CONTRACT.</p> <p>Purchase Order issued in accordance with Playground Guardian, LLC bid recieved on October 31, 2018 is hereby made part this contract.</p> <p>City Council approved on November 20, 2018</p> <p>Contract dates: December 1, 2018 to November 30, 2019</p> <p>Vendor Contact: Eddie LaRocque Phone No.: 877-984-0418 Fax No.: 704-525-7356 E-mail: eddie@playgroundguardian.com</p> <p>The undersigned hereby agrees to perform the services in accordance with the terms and conditions as set forth in this Purchase Order, the City of Chattanooga Standard Terms &amp; Conditions, and the bid or quotation.</p> <p>Representative: _____ Agreed to and accepted by: _____</p> <p>Title: _____ CITY OF CHATTANOOGA, TENNESSEE</p> <p>Date: _____ Name/Title: _____</p> <p style="margin-left: 200px;">Department: _____</p>	Line Nbr	Item ID - Item Description	Quantity	Unit	Unit Price	Total		
Line Nbr	Item ID - Item Description	Quantity	Unit	Unit Price	Total			

\*\*\*\*\* NOTICE \*\*\*\*\*

This Purchase Order ("Agreement") is a binding agreement between the City of Chattanooga and the Vendor. This Purchase Order shall be governed by the following documents: (1) Purchase Order; (2) City of Chattanooga Purchase Order Standard Terms and Conditions; (3) Vendor's response to the bid or quotation; and (4) terms and conditions set forth in the bid or quotation, each of which is hereby incorporated herein by reference and becomes a part of this Agreement. In the event any conflict of terms arises, the terms controlling the Agreement shall be in the order provided hereinabove. This Purchase Order is valid only when signed or electronically approved by the Finance Officer.

Electronic approval is on record in the purchasing information system which asserts that unencumbered appropriation is available to meet the expenditure covered by this Purchase Order, and further authorizes payment upon proper certification of receipt of goods and/or services.

# Purchase Order BLANKET



**City of Chattanooga**  
101 East 11th Street, Suite G13  
Chattanooga, TN 37402

<b>V E N D O R</b>	Vendor Number: Vendor Alternate ID: 986245  Playground Guardian LLC PO Box 240981 Charlotte, NC 28224
--	--

PO Date: 28-NOV-18 Buyer: Mark McKeel FOB: DESTINATION Terms: Immediate	<b>Purchase Order Number 552038</b>  INVOICES: Direct invoices in DUPLICATE to the Invoice address shown below.
--	---

<b>S H I P T O</b>	
--	--

<b>I N V O I C E</b>	Accounts Payable Division City of Chattanooga 101 East 11th Street, Suite 101 Chattanooga, TN 37402
--	--

Requestor			Requisition Number		Bid Number
Line Nbr	Item ID - Item Description	Quantity	Unit	Unit Price	Total
1	Playground Inspection, Safety Audit, per Site	0.00	Job	\$ 450.0000	\$ 0.00
2	Playground Inspection, One Time ADA Assessment, per Site	0.00	Job	\$ 200.0000	\$ 0.00
3	Playground Inspection, HIC & Gmax Analysis, per Site	0.00	Job	\$ 100.0000	\$ 0.00
4	Annual Training for Parks Staff; No Charge as long as Contract for Inspections is Valid	0.00	Year	\$ 1.0000	\$ 0.00
5	Permanent Access to Software at End of Contract; Free Full Access to Park Protector Software System during Contract Period	0.00	Each	\$ 1.0000	\$ 0.00

**TOTAL: \$ .00**

\*\*\*\*\* NOTICE \*\*\*\*\*

This Purchase Order ("Agreement") is a binding agreement between the City of Chattanooga and the Vendor. This Purchase Order shall be governed by the following documents: (1) Purchase Order; (2) City of Chattanooga Purchase Order Standard Terms and Conditions; (3) Vendor's response to the bid or quotation; and (4) terms and conditions set forth in the bid or quotation, each of which is hereby incorporated herein by reference and becomes a part of this Agreement. In the event any conflict of terms arises, the terms controlling the Agreement shall be in the order provided hereinabove. This Purchase Order is valid only when signed or electronically approved by the Finance Officer.

Electronic approval is on record in the purchasing information system which asserts that unencumbered appropriation is available to meet the expenditure covered by this Purchase Order; and further authorizes payment upon proper certification of receipt of goods and/or services.



# City of Chattanooga

Mayor Andy Berke

September 17, 2019

Mr. Justin Holland  
Administrator, Public Works Department  
Facilities Management Division  
1250 Market Street, Suite 2100  
Chattanooga, TN 37402

**Subject: Contract Renewal of Blanket PO No. 538199 – Knoll Open Office Landscape Furniture – City Wide – Facilities Management Division – Public Works Department**

Dear Mr. Holland:

Council approval is recommended to renew Blanket PO No. 538199 for Knoll Open Office Landscape Furniture, City Wide, Facilities Management Division, Public Works Department. The City of Chattanooga is renewing the fourth (4<sup>th</sup>) and final contract renewal option for twelve (12) months, for an estimated annual amount of \$250,000. A copy of the Omnia Partners Contract No. 440003404 is enclosed.

This blanket contract is from the Omnia Partners, formerly U.S. Communities, Contract No. 440003404 to Knoll, Inc. using CBI, who is the authorized dealer/distributor for Knoll Furniture located in Chattanooga. This contract will coincide with the Omnia Partners contract that has been extended through December 31, 2020. A copy of the Omnia Partners contract is attached.

TCA 6-56-304.2 allows this single source blanket contract exempted from the usual advertising and bidding requirements.

Page 2

**Knoll Open Office Landscape Furniture**

I recommend approval of this blanket contract to Knoll, Inc., using CBI, 701 Cherry Street, Suite 100, Chattanooga, TN 37402 through Omnia Partners based on the cooperative purchase stated above for the City of Chattanooga.

Respectfully yours,

A handwritten signature in blue ink that reads "Bonnie Woodward". The signature is written in a cursive, flowing style.

**Bonnie Woodward**  
**Director of Purchasing**

BW/mlm

**Attachments**

# Purchase Order BLANKET



**City of Chattanooga**  
101 East 11th Street, Suite G13  
Chattanooga, TN 37402

<b>V E N D O R</b>	Vendor Number: Vendor Alternate ID: 510144  <b>CBI</b> 701 Cherry St Ste 100 Chattanooga, TN 37402
--	---

PO Date: 13-MAY-16 Buyer: Mark McKeel FOB: DESTINATION Terms: Immediate	<b>Purchase Order Number</b> <b>538199</b>  INVOICES: Direct invoices in DUPLICATE to the Invoice address shown below.
--	---

<b>S H I P T O</b>	
--	--

<b>I N V O I C E</b>	Accounts Payable Division City of Chattanooga 101 East 11th Street, Suite 101 Chattanooga, TN 37402
--	--

Requestor		Requisition Number		Bid Number	
<b>Line Nbr</b>	<b>Item ID - Item Description</b>	<b>Quantity</b>	<b>Unit</b>	<b>Unit Price</b>	<b>Total</b>
Requisition / Bid No.: 134710 / 304249 Ordering Dept.: General Services Buyer: Mark McKeel Phone No.: 423-643-7236  Items Being Purchased: Knoll Open Office Landscape Furniture - U.S. Communities  This contract is to coincide with U.S. Communities Contract No. 4400003404 Current contract expires December 31, 2016. This contract has an additional four (4) options to renew. Contract will end December 31, 2020.  ATTACHMENTS: City of Chattanooga (COC) Terms and Conditions posted on Website <a href="http://www.chattanooga.gov/general-services/purchasing/standard-terms-and-conditions">http://www.chattanooga.gov/general-services/purchasing/standard-terms-and-conditions</a> If you can't download call buyer for a copy.  This Shall Be An Eight (8) Month Blanket Contract To Supply Knoll Open Office Landscape Furniture to General Services, Building Maintenance.  The Contract Term May Be Renewed For An Additional Four (4) Twelve (12) Month Term Under The Same Terms And Conditions By Mutual Agreement. The City Of Chattanooga And The Contractor May Bilaterally Extend The Contract By Providing Written Confirmation Of Agreement By Both Parties At Least 30 Days Prior To The Contract's Current Expiration Date Into Any Successive Term As Provided Herein.  **** Vendor Shall Hold Prices Firm for First (1st) Year of Contract ****  Price Escalation Clause: If as a result of a general change in prices or discounts, the Contractor has changed prices to all of its customers, the price under this contract may be adjusted accordingly. Contractor may be requested to show proof of alleged price changes prior to approval of any price adjustments.					

\*\*\*\*\* NOTICE \*\*\*\*\*

This Purchase Order ("Agreement") is a binding agreement between the City of Chattanooga and the Vendor. This Purchase Order shall be governed by the following documents: (1) Purchase Order; (2) City of Chattanooga Purchase Order Standard Terms and Conditions; (3) Vendor's response to the bid or quotation; and (4) terms and conditions set forth in the bid or quotation, each of which is hereby incorporated herein by reference and becomes a part of this Agreement. In the event any conflict of terms arises, the terms controlling the Agreement shall be in the order provided hereinabove. This Purchase Order is valid only when signed or electronically approved by the Finance Officer.

Electronic approval is on record in the purchasing information system which asserts that unencumbered appropriation is available to meet the expenditure covered by this Purchase Order; and further authorizes payment upon proper certification of receipt of goods and/or services.

# Purchase Order BLANKET



**City of Chattanooga**  
101 East 11th Street, Suite G13  
Chattanooga, TN 37402

<b>V E N D O R</b>	Vendor Number: Vendor Alternate ID: 510144  CBI 701 Cherry St Ste 100 Chattanooga, TN 37402
--	--

PO Date: 13-MAY-16 Buyer: Mark McKeel FOB: DESTINATION Terms: Immediate	<b>Purchase Order Number 538199</b>  INVOICES: Direct Invoices in DUPLICATE to the Invoice address shown below.
--	---

<b>S H I P T O</b>	
--	--

<b>I N V O I C E</b>	Accounts Payable Division City of Chattanooga 101 East 11th Street, Suite 101 Chattanooga, TN 37402
--	--

Requestor	Requisition Number	Bid Number																																																										
<table border="1" style="width: 100%; border-collapse: collapse;"> <thead> <tr> <th style="width: 10%;">Line Nbr</th> <th style="width: 40%;">Item ID - Item Description</th> <th style="width: 10%;">Quantity</th> <th style="width: 10%;">Unit</th> <th style="width: 10%;">Unit Price</th> <th style="width: 10%;">Total</th> </tr> </thead> <tr> <td colspan="6">                             QUANTITIES ARE ESTIMATES ONLY THE CITY OF CHATTANOOGA SHALL                              GUARANTEE NO MINIMUM OR MAXIMUM AMOUNT PURCHASED DURING                              THE LIFETIME OF THE CONTRACT.                         </td> </tr> <tr> <td colspan="6">                             Purchase Order issued in accordance with Knoll, Inc. through CBI using U.S. Communities                              Contract No. 4400003404 is hereby made part of this contract.                         </td> </tr> <tr> <td colspan="6">                             City Council approved on May 10, 2016                         </td> </tr> <tr> <td colspan="6">                             Contract dates: May 13, 2016 to December 31, 2016                              ** This coincides with the U.S. Communities contract **                         </td> </tr> <tr> <td colspan="3">                             Vendor Contact: Maccarena Blackhart                              Phone No.: 865-321-4902                              Cell No.: 206-484-6428                              E-mail: maccarena.blackhart@cbi-tn.com                         </td> <td colspan="3">                             Dean Vance                              Phone No.: 865-321-4901                              Cell No.: 865-223-2777                              E-mail: dean.vance@cbi-tn.com                         </td> </tr> <tr> <td colspan="6">                             The undersigned hereby agrees to perform the services in accordance with the terms and conditions as set forth in this Purchase Order, the City of Chattanooga Standard Terms &amp; Conditions, and the bid or quotation.                         </td> </tr> <tr> <td colspan="2">                             Representative: _____                         </td> <td colspan="4">                             Agreed to and accepted by: _____                         </td> </tr> <tr> <td colspan="2">                             Title: _____                         </td> <td colspan="4">                             CITY OF CHATTANOOGA, TENNESSEE                         </td> </tr> <tr> <td colspan="2">                             Date: _____                         </td> <td colspan="2">                             Name/Title: _____                         </td> <td colspan="2">                             Department: _____                         </td> </tr> </table>	Line Nbr	Item ID - Item Description	Quantity	Unit	Unit Price	Total	QUANTITIES ARE ESTIMATES ONLY THE CITY OF CHATTANOOGA SHALL GUARANTEE NO MINIMUM OR MAXIMUM AMOUNT PURCHASED DURING THE LIFETIME OF THE CONTRACT.						Purchase Order issued in accordance with Knoll, Inc. through CBI using U.S. Communities Contract No. 4400003404 is hereby made part of this contract.						City Council approved on May 10, 2016						Contract dates: May 13, 2016 to December 31, 2016 ** This coincides with the U.S. Communities contract **						Vendor Contact: Maccarena Blackhart Phone No.: 865-321-4902 Cell No.: 206-484-6428 E-mail: maccarena.blackhart@cbi-tn.com			Dean Vance Phone No.: 865-321-4901 Cell No.: 865-223-2777 E-mail: dean.vance@cbi-tn.com			The undersigned hereby agrees to perform the services in accordance with the terms and conditions as set forth in this Purchase Order, the City of Chattanooga Standard Terms & Conditions, and the bid or quotation.						Representative: _____		Agreed to and accepted by: _____				Title: _____		CITY OF CHATTANOOGA, TENNESSEE				Date: _____		Name/Title: _____		Department: _____	
Line Nbr	Item ID - Item Description	Quantity	Unit	Unit Price	Total																																																							
QUANTITIES ARE ESTIMATES ONLY THE CITY OF CHATTANOOGA SHALL GUARANTEE NO MINIMUM OR MAXIMUM AMOUNT PURCHASED DURING THE LIFETIME OF THE CONTRACT.																																																												
Purchase Order issued in accordance with Knoll, Inc. through CBI using U.S. Communities Contract No. 4400003404 is hereby made part of this contract.																																																												
City Council approved on May 10, 2016																																																												
Contract dates: May 13, 2016 to December 31, 2016 ** This coincides with the U.S. Communities contract **																																																												
Vendor Contact: Maccarena Blackhart Phone No.: 865-321-4902 Cell No.: 206-484-6428 E-mail: maccarena.blackhart@cbi-tn.com			Dean Vance Phone No.: 865-321-4901 Cell No.: 865-223-2777 E-mail: dean.vance@cbi-tn.com																																																									
The undersigned hereby agrees to perform the services in accordance with the terms and conditions as set forth in this Purchase Order, the City of Chattanooga Standard Terms & Conditions, and the bid or quotation.																																																												
Representative: _____		Agreed to and accepted by: _____																																																										
Title: _____		CITY OF CHATTANOOGA, TENNESSEE																																																										
Date: _____		Name/Title: _____		Department: _____																																																								

  |  |

\*\*\*\*\* NOTICE \*\*\*\*\*

This Purchase Order ("Agreement") is a binding agreement between the City of Chattanooga and the Vendor. This Purchase Order shall be governed by the following documents: (1) Purchase Order; (2) City of Chattanooga Purchase Order Standard Terms and Conditions; (3) Vendor's response to the bid or quotation; and (4) terms and conditions set forth in the bid or quotation, each of which is hereby incorporated herein by reference and becomes a part of this Agreement. In the event any conflict of terms arises, the terms controlling the Agreement shall be in the order provided hereinabove. This Purchase Order is valid only when signed or electronically approved by the Finance Officer.

Electronic approval is on record in the purchasing information system which asserts that unencumbered appropriation is available to meet the expenditure covered by this Purchase Order; and further authorizes payment upon proper certification of receipt of goods and/or services.



# Purchase Order BLANKET



**City of Chattanooga**  
101 East 11th Street, Suite G13  
Chattanooga, TN 37402

<b>V E N D O R</b>	Vendor Number: Vendor Alternate ID: 510144  CBI 701 Cherry St Ste 100 Chattanooga, TN 37402
--	--

PO Date: 13-MAY-16 Buyer: Mark McKeel FOB: DESTINATION Terms: Immediate	<b>Purchase Order Number 538199</b>  INVOICES: Direct invoices in DUPLICATE to the Invoice address shown below.
--	---

<b>S H I P T O</b>	
--	--

<b>I N V O I C E</b>	Accounts Payable Division City of Chattanooga 101 East 11th Street, Suite 101 Chattanooga, TN 37402
--	--

	Requestor	Requisition Number	Bid Number
Line Nbr	Item ID - Item Description	Quantity	Unit Price
	Total		
	Change Order #1 ***** Contract has been extended an additional twelve (12) months. New contract performance date is December 31, 2017. ***** City Council approved contract renewal on November 15, 2016. ***** 1st Renewal		

\*\*\*\*\* NOTICE \*\*\*\*\*

This Purchase Order ("Agreement") is a binding agreement between the City of Chattanooga and the Vendor. This Purchase Order shall be governed by the following documents: (1) Purchase Order; (2) City of Chattanooga Purchase Order Standard Terms and Conditions; (3) Vendor's response to the bid or quotation; and (4) terms and conditions set forth in the bid or quotation, each of which is hereby incorporated herein by reference and becomes a part of this Agreement. In the event any conflict of terms arises, the terms controlling the Agreement shall be in the order provided hereinabove. This Purchase Order is valid only when signed or electronically approved by the Finance Officer.

Electronic approval is on record in the purchasing information system which asserts that unencumbered appropriation is available to meet the expenditure covered by this Purchase Order; and further authorizes payment upon proper certification of receipt of goods and/or services.

# Purchase Order BLANKET



**City of Chattanooga**  
101 East 11th Street, Suite G13  
Chattanooga, TN 37402

<b>V E N D O R</b>	Vendor Number: Vendor Alternate ID: 510144  CBI 701 Cherry St Ste 100 Chattanooga, TN 37402
--	--

PO Date: 13-MAY-16 Buyer: Mark McKeel FOB: DESTINATION Terms: Immediate	<b>Purchase Order Number 538199</b>  INVOICES: Direct invoices in DUPLICATE to the Invoice address shown below.
--	---

<b>S H I P T O</b>	
--	--

<b>I N V O I C E</b>	Accounts Payable Division City of Chattanooga 101 East 11th Street, Suite 101 Chattanooga, TN 37402
--	--

Requestor		Requisition Number		Bid Number	
Line Nbr	Item ID - Item Description	Quantity	Unit	Unit Price	Total
	Change Order #2 ***** Contract has been extended an additional twelve (12) months. New contract performance date is December 31, 2018. ***** City Council approved contract renewal on December 5, 2017. ***** 2nd Renewal				

\*\*\*\*\* NOTICE \*\*\*\*\*

This Purchase Order ("Agreement") is a binding agreement between the City of Chattanooga and the Vendor. This Purchase Order shall be governed by the following documents: (1) Purchase Order; (2) City of Chattanooga Purchase Order Standard Terms and Conditions; (3) Vendor's response to the bid or quotation; and (4) terms and conditions set forth in the bid or quotation, each of which is hereby incorporated herein by reference and becomes a part of this Agreement. In the event any conflict of terms arises, the terms controlling the Agreement shall be in the order provided hereinabove. This Purchase Order is valid only when signed or electronically approved by the Finance Officer.

Electronic approval is on record in the purchasing information system which asserts that unencumbered appropriation is available to meet the expenditure covered by this Purchase Order; and further authorizes payment upon proper certification of receipt of goods and/or services.

# Purchase Order BLANKET



**City of Chattanooga**  
101 East 11th Street, Suite G13  
Chattanooga, TN 37402

<b>V E N D O R</b>	Vendor Number: Vendor Alternate ID: 510144
	<b>CBI</b> 701 Cherry St Ste 100 Chattanooga, TN 37402

PO Date: 13-MAY-16 Buyer: Mark McKeel FOB: DESTINATION Terms: Immediate	<b>Purchase Order Number</b> <b>538199</b>  INVOICES: Direct invoices in DUPLICATE to the Invoice address shown below.
--	---

<b>S H I P T O</b>	
--	--

<b>I N V O I C E</b>	Accounts Payable Division City of Chattanooga 101 East 11th Street, Suite 101 Chattanooga, TN 37402
--	--

Requestor		Requisition Number		Bid Number	
Line Nbr	Item ID - Item Description	Quantity	Unit	Unit Price	Total
2	Design Services	0.00	Hour	\$ 95.0000	\$ 0.00
3	Installation, Project Management, Reconfiguration, and Asset Management Rates; Non-Union (\$70.72 - \$94.28 per hour)	0.00	Hour	\$ 1.0000	\$ 0.00
4	Installation, Project Management, Reconfiguration, and Asset Management Rates; Union (\$140.31 - \$151.54 per Hour)-	0.00	Hour	\$ 1.0000	\$ 0.00
5	After Hours Installation, Project Management, Reconfiguration, and Asset Management Rates; Non-Union (\$106.08 - \$141.42 per Hour)	0.00	Hour	\$ 1.0000	\$ 0.00
6	After Hours Installation, Project Management, Reconfiguration, and Asset Management Rates; Union (\$210.47 - \$227.31 per Hour)	0.00	Hour	\$ 1.0000	\$ 0.00
7	Systems Furniture - Equity; See Chart for Discount Percent	0.00	Each	\$ 1.0000	\$ 0.00
8	Systems Furniture - Morrison, Reff, Reuter, Currents, AutoStrada, Dividends Horizon, Series 2, Antenna; See Chart for Discount Percent	0.00	Each	\$ 1.0000	\$ 0.00
14	Freestanding Furniture, Seating, Filing Systems and Equipment - Upstart, Template; See Chart for Discount Percent	0.00	Each	\$ 1.0000	\$ 0.00
15	Freestanding Furniture, Seating, Filing Systems and Equipment - Calibre, Interaction, Crinion Open Table, KnollExtra, Chadwick, Essentials Work Chairs, Sapper Seating, Life Seating, RPM Seating; See Chart for Discount Percent	0.00	Each	\$ 1.0000	\$ 0.00
16	Freestanding Furniture, Seating, Filing Systems and Equipment - Generation Seating, ReGeneration Seating, MultiGeneration Seating, Graham Collection; See Chart for Discount Percent	0.00	Each	\$ 1.0000	\$ 0.00

\*\*\*\*\* NOTICE \*\*\*\*\*

This Purchase Order ("Agreement") is a binding agreement between the City of Chattanooga and the Vendor. This Purchase Order shall be governed by the following documents: (1) Purchase Order; (2) City of Chattanooga Purchase Order Standard Terms and Conditions; (3) Vendor's response to the bid or quotation; and (4) terms and conditions set forth in the bid or quotation, each of which is hereby incorporated herein by reference and becomes a part of this Agreement. In the event any conflict of terms arises, the terms controlling the Agreement shall be in the order provided hereinabove. This Purchase Order is valid only when signed or electronically approved by the Finance Officer.

Electronic approval is on record in the purchasing information system which asserts that unencumbered appropriation is available to meet the expenditure covered by this Purchase Order; and further authorizes payment upon proper certification of receipt of goods and/or services.

# Purchase Order BLANKET



**City of Chattanooga**  
101 East 11th Street, Suite G13  
Chattanooga, TN 37402

<b>V E N D O R</b>	Vendor Number: Vendor Alternate ID: 510144
	CBI 701 Cherry St Ste 100 Chattanooga, TN 37402

PO Date: 13-MAY-16 Buyer: Mark McKeel FOB: DESTINATION Terms: Immediate	<b>Purchase Order Number</b> <b>538199</b>  INVOICES: Direct Invoices In DUPLICATE to the Invoice address shown below.
--	---

<b>S H I P T O</b>	
--	--

<b>I N V O I C E</b>	Accounts Payable Division City of Chattanooga 101 East 11th Street, Suite 101 Chattanooga, TN 37402
--	--

Requestor		Requisition Number		Bid Number	
Line Nbr	Item ID - Item Description	Quantity	Unit	Unit Price	Total
17	Freestanding Furniture, Seating, Filing Systems and Equipment - Moment Seating; See Chart for Discount Percent	0.00	Each	\$ 1.0000	\$ 0.00
18	Freestanding Furniture, Seating, Filing Systems and Equipment - KnollStudio including Spark Seating; See Chart for Discount Percent	0.00	Each	\$ 1.0000	\$ 0.00
19	Renewal / Replacement Parts; See Chart for Discount Percent	0.00	Each	\$ 1.0000	\$ 0.00

**TOTAL: \$ .00**

\*\*\*\*\* NOTICE \*\*\*\*\*

This Purchase Order ("Agreement") is a binding agreement between the City of Chattanooga and the Vendor. This Purchase Order shall be governed by the following documents: (1) Purchase Order; (2) City of Chattanooga Purchase Order Standard Terms and Conditions; (3) Vendor's response to the bid or quotation; and (4) terms and conditions set forth in the bid or quotation, each of which is hereby incorporated herein by reference and becomes a part of this Agreement. In the event any conflict of terms arises, the terms controlling the Agreement shall be in the order provided hereinabove. This Purchase Order is valid only when signed or electronically approved by the Finance Officer.

Electronic approval is on record in the purchasing information system which asserts that unencumbered appropriation is available to meet the expenditure covered by this Purchase Order; and further authorizes payment upon proper certification of receipt of goods and/or services.



# County of Fairfax, Virginia

## AMENDMENT

AMENDMENT NO. 18

**AUG 28 2017**

CONTRACT TITLE: Office Furniture and Related Services

CONTRACTOR  
Knoll, Inc.  
1235 Water Street  
East Greenville, PA18041

SUPPLIER CODE  
1000011430

CONTRACT NO.  
4400003404

By mutual agreement, Contract 4400003404 is renewed for three (3) years at existing prices, discounts, terms, and conditions, effective January 1, 2018, through December 31, 2020. There are no more renewal options remaining on this contract.

ACCEPTANCE:

BY: Andrew F. Pierce  
(Signature)

Director, Contracting  
(Title)

Andrew F. Pierce  
(Printed)

August 16, 2017  
(Date)

Cathy A. Muse  
Cathy A. Muse, CPPO  
Director/County Purchasing Agent

DISTRIBUTION

Department of Finance – Accounts Payable  
Facilities Management Dept. – Bill Robinson/e  
Facilities Management Dept. – Cathy Spaine/e  
Facilities Management Dept. – Rhinda Edwards/e  
Facilities Management Dept. – Christine Covey/e  
U. S. Communities – Corey Imhoff – [cimhoff@uscommunities.org](mailto:cimhoff@uscommunities.org)  
Contractor: [wayne\\_mcdorman@knoll.com](mailto:wayne_mcdorman@knoll.com)

Contract Specialist – G. Bright  
Asst. Contract Specialist - Team 2

Department of Procurement & Material Management  
12000 Government Center Parkway, Suite 427  
Fairfax, VA 22035-0013  
Website: [www.fairfaxcounty.gov/dpmm](http://www.fairfaxcounty.gov/dpmm)  
Phone 703-324-3201, TTY: 711, Fax: 703-324-3228



# County of Fairfax, Virginia

To protect and enrich the quality of life for the people, neighborhoods and diverse communities of Fairfax County

**OCT 10 2012**

Knoll, Inc.  
1235 Water Street  
East Greenville, PA 18041

Attention: Steve Robinson, Vice President

Reference: RFP2000000330 – Office Furniture and Related Services and Solutions

Dear Mr. Robinson:

## **ACCEPTANCE AGREEMENT**

**Contract Number: 4400003404**

This acceptance agreement signifies a contract award to Knoll, Inc. in its entirety for Office Furniture and Related Services and Solutions. The period of the contract is from January 1, 2013, through December 31, 2016, with four (4), one (1) year renewal options.

The contract award shall be in accordance with the following:

- 1) This Acceptance Agreement;
- 2) The signed Memorandum of Negotiations

Please note that this is not an order to proceed. A Purchase Order, which constitutes your notice to proceed, will be issued by the County. Please provide your Insurance Certificate according to Special Provisions paragraph 14 within ten (10) days of receipt of this letter. Contract award documents may be viewed on the Department of Purchasing and Supply Management website at [www.fairfaxcounty.gov/cregister](http://www.fairfaxcounty.gov/cregister).

Cathy A. Muse, CPPO  
Director/County Purchasing Agent

---

**Department of Purchasing and Supply Management**  
12000 Government Center Parkway, Suite 427  
Fairfax, VA 22035

Website: [www.fairfaxcounty.gov/dpsm](http://www.fairfaxcounty.gov/dpsm)

Phone: 703-324-3201, TTY: 1-800-828-1140, Fax: 703-324-3228



# County of Fairfax, Virginia

To protect and enrich the quality of life for the people, neighborhoods and diverse communities of Fairfax County

## MEMORANDUM OF NEGOTIATION

RFP2000000330

The County of Fairfax (hereinafter called the County) and Knoll, Inc. (hereinafter called the Contractor) hereby agree to the following in the execution of Contract 4400003404. The final contract contains the following items:

- a. Fairfax County's RFP2000000330
- b. All Addenda
- c. Knoll, Inc. Technical and Business proposal as amended by this Memorandum of Negotiations
- d. Response to clarifications dated August 8, and 9, 2012
- e. The Memorandum of Negotiations

The following and are to be included in the contract:

1. This contract will begin on January 1, 2013 and terminate on December 31, 2016. Fairfax County reserves the right to renew the contract for four (4) years, one (1) year at a time by mutual agreement.
2. Revised Cost Proposal Attachment A – Price Sheet – submitted via e-mail on September 7, 2012.

All other prices, terms, and conditions remain the same.

ACCEPTED BY:

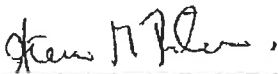

Steven M. Robinson, Vice President  
Knoll Inc.

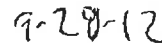

Date



Cathy A. Muse, CPPO  
Director/County Purchasing Agent

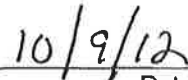

Date

**Department of Purchasing and Supply Management**

12000 Government Center Parkway, Suite 427

Fairfax, VA 22035

Website: [www.fairfaxcounty.gov/dpsm](http://www.fairfaxcounty.gov/dpsm)

Phone: 703-324-3201, TTY: 1-800-828-1140, Fax: 703-324-3228

REGISTER



# Knoll, Inc.

Office Furniture

# Knoll

REQUEST INFORMATION

**Overview**

Contract Documentation

**Seating**

**Storage**

**Tables and Desks**

**Workspaces**

**Accessories**



[New Products](#)[Higher Education Solutions](#)[Benefits](#)[FAQs](#)

*U.S. Communities and National IPA, both wholly-owned subsidiaries of OMNIA Partners, have come together as OMNIA Partners, Public Sector. All public sector participants already registered with National IPA or U.S. Communities continue to have access to all contracts, with certain exceptions, in the portfolio and do not need to re-register to use a legacy National IPA, legacy U.S. Communities, or new OMNIA Partners contract. U.S. Communities and National IPA remain separate legal entities and lead agency contracts completed under each brand are effective and available for use through the contract's approved term. In the event we believe re-registration is necessary for any reason, OMNIA Partners will let you know.*

## Office Furniture

### Lead Agency

Fairfax County, Virginia

### Contract Number

4400003404

4 year initial term, January 1, 2013 to December 31, 2016

Option to renew for (4) additional (1) year periods

**Contract has been extended through December 31, 2020**

### Executive Summary

- Uniform Guidance

### Contract Documents

- Contract 4400003404
- Notice of Award
- Contract Amendments

### RFP Documents

- Request for Proposal
- 2000000330 Addenda
- RFP Posting Document



# City of Chattanooga

Mayor Andy Berke

September 17, 2019

Mr. Justin Holland  
Administrator, Public Works Department  
Fleet Management Division  
1250 Market Street, Suite 2100  
Chattanooga, TN 37402

**Subject: Contract Renewal of Blanket PO No. 551823 – Setina Police Vehicle Equipment –  
Fleet Management Division – Public Works Department**

Dear Mr. Holland:

Council approval is recommended to renew Blanket PO No. 551823 for Setina Police Vehicle Equipment, Fleet Management Division, Public Works Department. The City of Chattanooga is renewing the first (1<sup>st</sup>) contract renewal option for twelve (12) months, with one (1) renewal option remaining, for an estimated annual amount of \$100,000. The renewal will include a price increase.

The original invitation to bid was sent to seven (7) vendors as well as formally advertised. Bids were received from five (5) vendors. Bid is retained on file in the Purchasing Office for your review upon request.

I recommend renewing Blanket PO No. 551823 for Setina Police Vehicle Equipment to Lee-Smith, Inc, 2600 8<sup>th</sup> Street, Chattanooga, TN 37407.

Respectfully yours,

Bonnie Woodward  
Director of Purchasing

BW/mlm

Attachments

**Setina Police Vehicle Equipment;  
Req# 177111**

Lee-Smith, Inc

LINE	CLASS-ITEM	UNIT OF MEASURE	2018 UNIT PRICE	UNIT OF MEASURE	2019 UNIT PRICE
1	Setina Rear Dcargob Barrier	Each	\$ 291.97	Each	\$ 325.75
2	Setina Prisoner Partition 10XL	Each	\$ 497.97	Each	\$ 525.75
3	Setina Singel/AR Mount	Each	\$ 199.27	Each	\$ 231.25
4	Setina Steel Rear Window Armor	Each	\$ 142.62	Each	\$ 180.10

\$ 1,131.83      \$ 1,262.85      10.0%

# Purchase Order BLANKET



**City of Chattanooga**  
101 East 11th Street, Suite G13  
Chattanooga, TN 37402

<b>V E N D O R</b>	Vendor Number: Vendor Alternate ID: 83947  Lee-Smith Inc 2600 8th Avenue Chattanooga, TN 37407
--	---

PO Date: 09-NOV-18 Buyer: Mark McKeel FOB: DESTINATION Terms: Immediate	<b>Purchase Order Number 551823</b>  INVOICES: Direct invoices in DUPLICATE to the Invoice address shown below.
--	---

<b>S H I P T O</b>	
--	--

<b>I N V O I C E</b>	Accounts Payable Division City of Chattanooga 101 East 11th Street, Suite 101 Chattanooga, TN 37402
--	--

Requestor		Requisition Number		Bid Number	
Line Nbr	Item ID - Item Description	Quantity	Unit	Unit Price	Total
Requisition / Bid No.: 177111 / 305253 Ordering Dept.: Fleet Management Division, Public Works Department Buyer: Mark McKeel Phone No.: 423-643-7236  Items Being Purchased: Setina Police Vehicle Equipment (no substitution)  This Shall Be A Twelve (12) Month Blanket Contract To Supply Setina Police Vehicle Equipment to Fleet Management Division.  The Contract Term May Be Renewed For An Additional Two (2) Twelve (12) Month Terms Under The Same Terms And Conditions By Mutual Agreement. The City Of Chattanooga And The Contractor May Bilaterally Extend The Contract By Providing Written Confirmation Of Agreement By Both Parties At Least 30 Days Prior To The Contract's Current Expiration Date Into Any Successive Term As Provided Herein.  **** Vendor Shall Hold Prices Firm for First (1st) Year of Contract ****  Price Escalation Clause: If as a result of a general change in prices or discounts, the Contractor has changed prices to all of its customers, the price under this contract may be adjusted accordingly. Contractor may be requested to show proof of alleged price changes prior to approval of any price adjustments.					

\*\*\*\*\* NOTICE \*\*\*\*\*

This Purchase Order ("Agreement") is a binding agreement between the City of Chattanooga and the Vendor. This Purchase Order shall be governed by the following documents: (1) Purchase Order; (2) City of Chattanooga Purchase Order Standard Terms and Conditions; (3) Vendor's response to the bid or quotation; and (4) terms and conditions set forth in the bid or quotation, each of which is hereby incorporated herein by reference and becomes a part of this Agreement. In the event any conflict of terms arises, the terms controlling the Agreement shall be in the order provided hereinabove. This Purchase Order is valid only when signed or electronically approved by the Finance Officer.

Electronic approval is on record in the purchasing information system which asserts that unencumbered appropriation is available to meet the expenditure covered by this Purchase Order; and further authorizes payment upon proper certification of receipt of goods and/or services.

# Purchase Order BLANKET



**City of Chattanooga**  
101 East 11th Street, Suite G13  
Chattanooga, TN 37402

<b>V E N D O R</b>	Vendor Number: Vendor Alternate ID: 83947  Lee-Smith Inc 2600 8th Avenue Chattanooga, TN 37407
--	---

PO Date: 09-NOV-18 Buyer: Mark McKeel FOB: DESTINATION Terms: Immediate	<b>Purchase Order Number 551823</b>  INVOICES: Direct invoices in DUPLICATE to the Invoice address shown below.
--	---

<b>S H I P T O</b>	
--	--

<b>I N V O I C E</b>	Accounts Payable Division City of Chattanooga 101 East 11th Street, Suite 101 Chattanooga, TN 37402
--	--

Requestor	Requisition Number	Bid Number						
<table border="1" style="width: 100%; border-collapse: collapse;"> <thead> <tr> <th style="width: 10%;">Line Nbr</th> <th style="width: 40%;">Item ID - Item Description</th> <th style="width: 10%;">Quantity</th> <th style="width: 10%;">Unit</th> <th style="width: 10%;">Unit Price</th> <th style="width: 10%;">Total</th> </tr> </thead> </table> <p>QUANTITIES ARE ESTIMATES ONLY THE CITY OF CHATTANOOGA SHALL GUARANTEE NO MINIMUM OR MAXIMUM AMOUNT PURCHASED DURING THE LIFETIME OF THE CONTRACT.</p> <p>Purchase Order issued in accordance with Lee-Smith, Inc bid received on October 24, 2018 is hereby made part of this contract.</p> <p>City Council approved on November 6, 2018</p> <p>Contract dates: November 12, 2018 to November 11, 2019</p> <p>Vendor Contact: Michael Shelton Phone No.: 423-622-4161 Fax No.: 423-493-4807 E-mail: mshelton@lee-smith.com</p> <p>The undersigned hereby agrees to perform the services in accordance with the terms and conditions as set forth in this Purchase Order, the City of Chattanooga Standard Terms &amp; Conditions, and the bid or quotation.</p> <p>Representative: _____ Agreed to and accepted by: _____                      Title: _____ CITY OF CHATTANOOGA, TENNESSEE                      Date: _____ Name/Title: _____                      Department: _____</p>	Line Nbr	Item ID - Item Description	Quantity	Unit	Unit Price	Total		
Line Nbr	Item ID - Item Description	Quantity	Unit	Unit Price	Total			

\*\*\*\*\* NOTICE \*\*\*\*\*

This Purchase Order ("Agreement") is a binding agreement between the City of Chattanooga and the Vendor. This Purchase Order shall be governed by the following documents: (1) Purchase Order; (2) City of Chattanooga Purchase Order Standard Terms and Conditions; (3) Vendor's response to the bid or quotation; and (4) terms and conditions set forth in the bid or quotation, each of which is hereby incorporated herein by reference and becomes a part of this Agreement. In the event any conflict of terms arises, the terms controlling the Agreement shall be in the order provided hereinabove. This Purchase Order is valid only when signed or electronically approved by the Finance Officer.

Electronic approval is on record in the purchasing information system which asserts that unencumbered appropriation is available to meet the expenditure covered by this Purchase Order, and further authorizes payment upon proper certification of receipt of goods and/or services.

# Purchase Order BLANKET



**City of Chattanooga**  
101 East 11th Street, Suite G13  
Chattanooga, TN 37402

<b>V E N D O R</b>	Vendor Number: Vendor Alternate ID: 83947  Lee-Smith Inc 2600 8th Avenue Chattanooga, TN 37407
--	---

PO Date: 09-NOV-18 Buyer: Mark McKeel FOB: DESTINATION Terms: Immediate	<b>Purchase Order Number 551823</b>  INVOICES: Direct invoices in DUPLICATE to the Invoice address shown below.
--	---

<b>S H I P T O</b>	
--	--

<b>I N V O I C E</b>	Accounts Payable Division City of Chattanooga 101 East 11th Street, Suite 101 Chattanooga, TN 37402
--	--

Requestor			Requisition Number		Bid Number
Line Nbr	Item ID - Item Description	Quantity	Unit	Unit Price	Total
1	Setina Rear Cargo Barrier-Item PK0316ITU122ND	0.00	Each	\$ 291.9700	\$ 0.00
2	Setina Prisoner Partition 10XL-Item PK1129ITU12SSCA	0.00	Each	\$ 497.9700	\$ 0.00
3	Setina Single AR Mount-Item GK10271UHKSSCAXL	0.00	Each	\$ 199.2700	\$ 0.00
4	Setina Steel Rear Window Armor-Item WK0514ITU12	0.00	Each	\$ 142.6200	\$ 0.00

**TOTAL: \$ .00**

\*\*\*\*\* NOTICE \*\*\*\*\*

This Purchase Order ("Agreement") is a binding agreement between the City of Chattanooga and the Vendor. This Purchase Order shall be governed by the following documents: (1) Purchase Order; (2) City of Chattanooga Purchase Order Standard Terms and Conditions; (3) Vendor's response to the bid or quotation; and (4) terms and conditions set forth in the bid or quotation, each of which is hereby incorporated herein by reference and becomes a part of this Agreement. In the event any conflict of terms arises, the terms controlling the Agreement shall be in the order provided hereinabove. This Purchase Order is valid only when signed or electronically approved by the Finance Officer.

Electronic approval is on record in the purchasing information system which asserts that unencumbered appropriation is available to meet the expenditure covered by this Purchase Order; and further authorizes payment upon proper certification of receipt of goods and/or services.



# City of Chattanooga

Mayor Andy Berke

September 17, 2019

Mr. Justin Holland  
Administrator, Public Works Department  
Parks Division  
1250 Market Street, Suite 2100  
Chattanooga, TN 37402

**Subject: Contract Renewal of Blanket PO No. 552015 – Irrigation System Repair Services – Parks Division – Public Works Department**

Dear Mr. Holland:

Council approval is recommended to renew Blanket PO No. 552015 for Irrigation System Repair Services, Parks Division, Public Works Department. The City of Chattanooga is renewing the first (1<sup>st</sup>) contract renewal option for twelve (12) months, with one (1) renewal option remaining for an estimated annual amount of \$35,000. A copy of the contract is enclosed.

The original invitation to bid was sent to eight (8) vendors as well as formally advertised. Bids were received from three (3) vendors. Bid is retained on file in the Purchasing Office for your review upon request.

I recommend renewing Blanket PO No. 552015 for Irrigation System Repair Services to Lawn Pro's of Chattanooga, P.O. Box 21892, Chattanooga, TN 37424.

Respectfully yours,

Bonnie Woodward  
Director of Purchasing

BW/mlm

Attachments

# Purchase Order BLANKET



**City of Chattanooga**  
101 East 11th Street, Suite G13  
Chattanooga, TN 37402

<b>V E N D O R</b>	Vendor Number: Vendor Alternate ID: 131004  Lawn Pros of Chattanooga PO Box 21892 Chattanooga, TN 37424
--	--

PO Date: 27-NOV-18 Buyer: Mark McKeel FOB: DESTINATION Terms: Immediate	<b>Purchase Order Number 552015</b>  INVOICES: Direct invoices in DUPLICATE to the Invoice address shown below.
--	---

<b>S H I P T O</b>	
--	--

<b>I N V O I C E</b>	Accounts Payable Division City of Chattanooga 101 East 11th Street, Suite 101 Chattanooga, TN 37402
--	--

	Requestor	Requisition Number	Bid Number
<b>Line Nbr</b>	<b>Item ID - Item Description</b>	<b>Quantity</b>	<b>Unit Price</b>
Requisition / Bid No.: 177181 / 305252 Ordering Dept.: Parks Division, Public Works Department Buyer: Mark McKeel Phone No.: 423-643-7236  Items Being Purchased: Irrigation System Repair Services  ATTACHMENTS: City of Chattanooga (COC) Terms and Conditions posted on Website <a href="http://www.chattanooga.gov/purchasing/standard-terms-and-conditions">http://www.chattanooga.gov/purchasing/standard-terms-and-conditions</a> If you can't download call buyer for a copy.  This Shall Be A Twelve (12) Month Blanket Contract To Supply Irrigation System Repair Services for Parks Division.  The Contract Term May Be Renewed For An Additional Two (2) Twelve (12) Month Terms Under The Same Terms And Conditions By Mutual Agreement. The City Of Chattanooga And The Contractor May Bilaterally Extend The Contract By Providing Written Confirmation Of Agreement By Both Parties At Least 30 Days Prior To The Contract's Current Expiration Date Into Any Successive Term As Provided Herein.  **** Vendor Shall Hold Prices Firm for First (1st) Year of Contract ****  Price Escalation Clause: If as a result of a general change in prices or discounts, the Contractor has changed prices to all of its customers, the price under this contract may be adjusted accordingly. Contractor may be requested to show proof of alleged price changes prior to approval of any price adjustments.			
<b>Total</b>			

\*\*\*\*\* NOTICE \*\*\*\*\*

This Purchase Order ("Agreement") is a binding agreement between the City of Chattanooga and the Vendor. This Purchase Order shall be governed by the following documents: (1) Purchase Order; (2) City of Chattanooga Purchase Order Standard Terms and Conditions; (3) Vendor's response to the bid or quotation; and (4) terms and conditions set forth in the bid or quotation, each of which is hereby incorporated herein by reference and becomes a part of this Agreement. In the event any conflict of terms arises, the terms controlling the Agreement shall be in the order provided hereinabove. This Purchase Order is valid only when signed or electronically approved by the Finance Officer.

Electronic approval is on record in the purchasing information system which asserts that unencumbered appropriation is available to meet the expenditure covered by this Purchase Order; and further authorizes payment upon proper certification of receipt of goods and/or services.



# Purchase Order BLANKET



**City of Chattanooga**  
101 East 11th Street, Suite G13  
Chattanooga, TN 37402

<b>V E N D O R</b>	Vendor Number: Vendor Alternate ID: 131004  Lawn Pros of Chattanooga PO Box 21892 Chattanooga, TN 37424
--	--

PO Date: 27-NOV-18 Buyer: Mark McKeel FOB: DESTINATION Terms: Immediate	<b>Purchase Order Number 552015</b>  INVOICES: Direct invoices in DUPLICATE to the Invoice address shown below.
--	---

<b>S H I P T O</b>	
--	--

<b>I N V O I C E</b>	Accounts Payable Division City of Chattanooga 101 East 11th Street, Suite 101 Chattanooga, TN 37402
--	--

Requestor	Requisition Number	Bid Number
-----------	--------------------	------------

Line Nbr	Item ID - Item Description	Quantity	Unit	Unit Price	Total
----------	----------------------------	----------	------	------------	-------

QUANTITIES ARE ESTIMATES ONLY THE CITY OF CHATTANOOGA SHALL GUARANTEE NO MINIMUM OR MAXIMUM AMOUNT PURCHASED DURING THE LIFETIME OF THE CONTRACT.

Purchase Order issued in accordance with Lawn Pro's of Chattanooga bid received on October 31, 2018 is hereby made part of this contract.

City Council approved on November 20, 2018

Contract dates: December 1, 2018 to November 30, 2019

Vendor Contact: Sam Bratton  
Phone No.: 423-667-1787  
sbratton@lawnproschattanooga.com

The undersigned hereby agrees to perform the services in accordance with the terms and conditions as set forth in this Purchase Order, the City of Chattanooga Standard Terms & Conditions, and the bid or quotation.

Representative: \_\_\_\_\_ Agreed to and accepted by: \_\_\_\_\_  
 Title: \_\_\_\_\_ CITY OF CHATTANOOGA, TENNESSEE  
 Date: \_\_\_\_\_ Name/Title: \_\_\_\_\_  
 Department: \_\_\_\_\_

\*\*\*\*\* NOTICE \*\*\*\*\*

This Purchase Order ("Agreement") is a binding agreement between the City of Chattanooga and the Vendor. This Purchase Order shall be governed by the following documents: (1) Purchase Order; (2) City of Chattanooga Purchase Order Standard Terms and Conditions; (3) Vendor's response to the bid or quotation; and (4) terms and conditions set forth in the bid or quotation, each of which is hereby incorporated herein by reference and becomes a part of this Agreement. In the event any conflict of terms arises, the terms controlling the Agreement shall be in the order provided hereinabove. This Purchase Order is valid only when signed or electronically approved by the Finance Officer.

Electronic approval is on record in the purchasing information system which asserts that unencumbered appropriation is available to meet the expenditure covered by this Purchase Order; and further authorizes payment upon proper certification of receipt of goods and/or services.

# Purchase Order BLANKET



**City of Chattanooga**  
101 East 11th Street, Suite G13  
Chattanooga, TN 37402

<b>V E N D O R</b>	Vendor Number: Vendor Alternate ID: 131004  Lawn Pros of Chattanooga PO Box 21892 Chattanooga, TN 37424
--	--

PO Date: 27-NOV-18 Buyer: Mark McKeel FOB: DESTINATION Terms: Immediate	<b>Purchase Order Number 552015</b>  INVOICES: Direct invoices in DUPLICATE to the Invoice address shown below.
--	---

<b>S H I P T O</b>	
--	--

<b>I N V O I C E</b>	Accounts Payable Division City of Chattanooga 101 East 11th Street, Suite 101 Chattanooga, TN 37402
--	--

Requestor			Requisition Number		Bid Number
Line Nbr	Item ID - Item Description	Quantity	Unit	Unit Price	Total
1	Service Technician Labor	0.00	Hour	\$ 35.0000	\$ 0.00
2	Service Technician Labor OT	0.00	Hour	\$ 50.0000	\$ 0.00
3	Water Analysis Technician	0.00	Hour	\$ 45.0000	\$ 0.00
4	Trencher	0.00	Hour	\$ 50.0000	\$ 0.00
5	Skid Steer	0.00	Hour	\$ 65.0000	\$ 0.00
6	Mini-excavator	0.00	Hour	\$ 65.0000	\$ 0.00
7	Materials; 10 % Markup	0.00	Each	\$ 1.0000	\$ 0.00
8	Turf Replacement; 10 % Markup	0.00	Each	\$ 1.0000	\$ 0.00
9	Specialized Equipment Rental; 10 % Markup	0.00	Each	\$ 1.0000	\$ 0.00

**TOTAL: \$ .00**

\*\*\*\*\* NOTICE \*\*\*\*\*

This Purchase Order ("Agreement") is a binding agreement between the City of Chattanooga and the Vendor. This Purchase Order shall be governed by the following documents: (1) Purchase Order; (2) City of Chattanooga Purchase Order Standard Terms and Conditions; (3) Vendor's response to the bid or quotation; and (4) terms and conditions set forth in the bid or quotation, each of which is hereby incorporated herein by reference and becomes a part of this Agreement. In the event any conflict of terms arises, the terms controlling the Agreement shall be in the order provided hereinabove. This Purchase Order is valid only when signed or electronically approved by the Finance Officer.

Electronic approval is on record in the purchasing information system which asserts that unencumbered appropriation is available to meet the expenditure covered by this Purchase Order; and further authorizes payment upon proper certification of receipt of goods and/or services.



# City of Chattanooga

Mayor Andy Berke

September 12, 2019

**Mr. Justin Holland**  
Administrator, Public Works Department  
Waste Resources Division  
1250 Market Street, Suite 2100  
Chattanooga, TN 37402

**Subject: Contract Renewal of Blanket PO No. 552043 Manhole Inspection Services – Waste Resources Division - Public Works**

**Dear Mr. Holland:**

The Public Works Department may now seek Council approval to renew Blanket PO No. 552403 Manhole Inspection Services for the Waste Resources Division. The City of Chattanooga is renewing the first (1st) contract renewal option for twelve (12) months, for a total estimated annual amount of \$250,000. A copy of the contract is enclosed.

The invitation to bid was sent out to eleven (11) vendors as well as formally advertised. Bids were received from eleven (11) vendors. Bids are retained on file in the Purchasing Office for your review upon request.

I recommend renewing Blanket PO No. 552403 Manhole Inspection Services to Compliance EnviroSystems, LLC., 1401 Seabord Drive, Baton Rouge, LA 70810.

Respectfully yours,

**Bonnie Woodward**  
Director of Purchasing

BW/ab

Attachments

# Purchase Order BLANKET



**City of Chattanooga**  
101 East 11th Street, Suite G13  
Chattanooga, TN 37402

<b>V E N D O R</b>	Vendor Number: Vendor Alternate ID: 986239  <b>Compliance Envirosystems LLC</b> 1401 Seaboard Dr Baton Rouge, LA 70810-6262
--	--

PO Date: 28-NOV-18 Buyer: Amanda Berkowitz FOB: DESTINATION Terms: Immediate	<b>Purchase Order Number</b> <b>552043</b>  INVOICES: Direct invoices in DUPLICATE to the Invoice address shown below.
---	---

<b>S H I P T O</b>	
--	--

<b>I N V O I C E</b>	Accounts Payable Division City of Chattanooga 101 East 11th Street, Suite 101 Chattanooga, TN 37402
--	--

Requestor		Requisition Number		Bid Number	
<b>Line Nbr</b>	<b>Item ID - Item Description</b>	<b>Quantity</b>	<b>Unit</b>	<b>Unit Price</b>	<b>Total</b>
Requisition / Bid No.: 176697 / 305247 Ordering Dept.: Waste Resource Division, Public Works Department Buyer: Mark McKeel Phone No.: 423-643-7236  Items Being Purchased: Sanitary Sewer Manhole Inspection Services  ATTACHMENTS: City of Chattanooga (COC) Terms and Conditions posted on Website <a href="http://www.chattanooga.gov/purchasing/standard-terms-and-conditions">http://www.chattanooga.gov/purchasing/standard-terms-and-conditions</a> If you can't download call buyer for a copy.  This Shall Be A Twelve (12) Month Blanket Contract To Supply Sanitary Sewer Manhole Inspection Services for Waste Resource Division.  The Contract Term May Be Renewed For An Additional Two (2) Twelve (12) Month Terms Under The Same Terms And Conditions By Mutual Agreement, The City Of Chattanooga And The Contractor May Bilaterally Extend The Contract By Providing Written Confirmation Of Agreement By Both Parties At Least 30 Days Prior To The Contract's Current Expiration Date Into Any Successive Term As Provided Herein.  **** Vendor Shall Hold Prices Firm for First (1st) Year of Contract ****  Price Escalation Clause: If as a result of a general change in prices or discounts, the Contractor has changed prices to all of its customers, the price under this contract may be adjusted accordingly. Contractor may be requested to show proof of alleged price changes prior to approval of any price adjustments.					

\*\*\*\*\* NOTICE \*\*\*\*\*

This Purchase Order ("Agreement") is a binding agreement between the City of Chattanooga and the Vendor. This Purchase Order shall be governed by the following documents: (1) Purchase Order; (2) City of Chattanooga Purchase Order Standard Terms and Conditions; (3) Vendor's response to the bid or quotation; and (4) terms and conditions set forth in the bid or quotation, each of which is hereby incorporated herein by reference and becomes a part of this Agreement. In the event any conflict of terms arises, the terms controlling the Agreement shall be in the order provided hereinabove. This Purchase Order is valid only when signed or electronically approved by the Finance Officer.

Electronic approval is on record in the purchasing information system which asserts that unencumbered appropriation is available to meet the expenditure covered by this Purchase Order; and further authorizes payment upon proper certification of receipt of goods and/or services.

# Purchase Order BLANKET



**City of Chattanooga**  
101 East 11th Street, Suite G13  
Chattanooga, TN 37402

<b>V E N D O R</b>	Vendor Number: Vendor Alternate ID: 986239  Compliance EnviroSystems LLC 1401 Seaboard Dr Baton Rouge, LA 70810-6262
--	---

PO Date: 28-NOV-18 Buyer: Amanda Berkowitz FOB: DESTINATION Terms: Immediate
---

<b>Purchase Order Number</b> <b>552043</b>  INVOICES: Direct invoices in DUPLICATE to the Invoice address shown below.
---

<b>S H I P T O</b>	
--	--

<b>I N V O I C E</b>	Accounts Payable Division City of Chattanooga 101 East 11th Street, Suite 101 Chattanooga, TN 37402
--	--

Requestor	Requisition Number	Bid Number
Line Nbr   Item ID - Item Description   Quantity   Unit   Unit Price   Total		
QUANTITIES ARE ESTIMATES ONLY THE CITY OF CHATTANOOGA SHALL GUARANTEE NO MINIMUM OR MAXIMUM AMOUNT PURCHASED DURING THE LIFETIME OF THE CONTRACT.		
Purchase Order issued in accordance with Compliance EnviroSystems, LLC received on November 6, 2018 is hereby made part of this contract.		
City Council approved on November 20, 2018		
Contract dates: December 1, 2018 to November 30, 2019		
Vendor Contact: Morgan Stafford Toll Free No.: 1-800-675-9409 Fax No.: 225-769-2929 E-mail: mstafford@ces-sses.com		
The undersigned hereby agrees to perform the services in accordance with the terms and conditions as set forth in this Purchase Order, the City of Chattanooga Standard Terms & Conditions, and the bid or quotation.		
Representative: _____	Agreed to and accepted by: _____	
Title: _____	CITY OF CHATTANOOGA, TENNESSEE	
Date: _____	Name/Title: _____	
	Department: _____	

\*\*\*\*\* NOTICE \*\*\*\*\*

This Purchase Order ("Agreement") is a binding agreement between the City of Chattanooga and the Vendor. This Purchase Order shall be governed by the following documents: (1) Purchase Order; (2) City of Chattanooga Purchase Order Standard Terms and Conditions; (3) Vendor's response to the bid or quotation; and (4) terms and conditions set forth in the bid or quotation, each of which is hereby incorporated herein by reference and becomes a part of this Agreement. In the event any conflict of terms arises, the terms controlling the Agreement shall be in the order provided hereinabove. This Purchase Order is valid only when signed or electronically approved by the Finance Officer.

Electronic approval is on record in the purchasing information system which asserts that unencumbered appropriation is available to meet the expenditure covered by this Purchase Order, and further authorizes payment upon proper certification of receipt of goods and/or services.

# Purchase Order BLANKET



**City of Chattanooga**  
101 East 11th Street, Suite G13  
Chattanooga, TN 37402

<b>V E N D O R</b>	Vendor Number: Vendor Alternate ID: 986239
	Compliance Envirosystems LLC 1401 Seabord Dr Baton Rouge, LA 70810-6262

PO Date: 28-NOV-18 Buyer: Amanda Berkowitz FOB: DESTINATION Terms: Immediate	<b>Purchase Order Number 552043</b>  INVOICES: Direct invoices in DUPLICATE to the Invoice address shown below.
---	---

<b>S H I P T O</b>	
--	--

<b>I N V O I C E</b>	Accounts Payable Division City of Chattanooga 101 East 11th Street, Suite 101 Chattanooga, TN 37402
--	--

Requestor		Requisition Number			Bid Number
Line Nbr	Item ID - Item Description	Quantity	Unit	Unit Price	Total
1	Level 1 Manhole Inspections - On Road	0.00	Each	\$ 58.0000	\$ 0.00
2	Level 1 Manhole Inspections - Off Road	0.00	Each	\$ 68.0000	\$ 0.00
3	Level 2 Manhole Inspections - On Road	0.00	Each	\$ 85.0000	\$ 0.00
4	Level 2 Manhole Inspections - Off Road	0.00	Each	\$ 95.0000	\$ 0.00

**TOTAL: \$ .00**

\*\*\*\*\* NOTICE \*\*\*\*\*

This Purchase Order ("Agreement") is a binding agreement between the City of Chattanooga and the Vendor. This Purchase Order shall be governed by the following documents: (1) Purchase Order; (2) City of Chattanooga Purchase Order Standard Terms and Conditions; (3) Vendor's response to the bid or quotation, and (4) terms and conditions set forth in the bid or quotation, each of which is hereby incorporated herein by reference and becomes a part of this Agreement. In the event any conflict of terms arises, the terms controlling the Agreement shall be in the order provided hereinabove. This Purchase Order is valid only when signed or electronically approved by the Finance Officer.

Electronic approval is on record in the purchasing information system which asserts that unencumbered appropriation is available to meet the expenditure covered by this Purchase Order; and further authorizes payment upon proper certification of receipt of goods and/or services.



# City of Chattanooga

Mayor Andy Berke

September 17, 2019

Mr. Justin Holland  
Administrator, Public Works Department  
City Wide Services Division  
1250 Market Street, Suite 2100  
Chattanooga, TN 37402

Subject: 189118 / 305631 – Tire Disposal & Recycling Services – City Wide Services  
Division – Public Works Department

Dear Mr. Holland:

The Public Works Department may now seek Council approval to issue a blanket contract for Tire Disposal & Recycling Services for the City Wide Services Division. The contract will be for twelve (12) months with the option to renew for two (2) additional twelve (12) month terms. The estimated annual expenditure for this contract is not to exceed \$30,000.

The invitation to bid was sent to seven (7) vendors as well as formally advertised. Bids were received from two (2) vendors shown below. Bids are retained on file in the Purchasing Office for your review upon request.

Vendors

Liberty Tire Recycling

Patriot Recycling

I recommend awarding the blanket contract for Tire Disposal & Recycling Services to Liberty Tire Recycling, 1700 Transport Way, Knoxville, TN 37924, as the best complete bid meeting specifications for the City of Chattanooga.

Respectfully yours,

Bonnie Woodward  
Director of Purchasing

BW/mlm

Attachments

**Bid Tabulation - Bid No. 305631/ Req No. 189118  
Tire Disposal & Recycling Services**

Item #	Description	Liberty Tire Recycling			Patriot Recycling		
		Unit	Unit Price	Extended Price	Unit Price	Quantity	Extended Price
1	Disposal of Tires (priced per ton)	Ton	\$ 114.47	\$ 28,617.50	\$ 265.00	250	\$ 66,250.00
<b>TOTAL:</b>				<b>\$ 28,617.50</b>			<b>\$ 66,250.00</b>
Contact: Location: Pymt Terms:		Bryan Crawford 1700 Transport Way Knoxville, TN 37924 net 30			Brent Miller 247 North Industrial Drive Bristol, TN 37620 net 30		



**Liberty Tire Recycling**  
1700 Transport Way  
Knoxville, TN 37924

**Goodyear Commercial & Service  
Center**  
3206 Alton Park Blvd  
Chattanooga, TN 37410

**Georgia Tire Recovery**  
167 Adams Road  
Meansville, GA 30256

**Patriot Recycling**  
247 North Industrial Drive  
Bristol, TN 37620

**Best One Tire**  
2348 Rossville Blvd  
Chattanooga, TN 37408

**Quality Tire Pro's**  
322 Cherokee Blvd  
Chattanooga, TN 37405

**JDOG Junk Removal & Hauling  
Services**  
850 Cassatt Road  
Berwyn, PA 19312

Date: August 21, 2019

Requisition No.: 189118

**PURCHASING DEPARTMENT  
101 EAST 11<sup>TH</sup> STREET  
CITY HALL  
SUITE G13  
CHATTANOOGA, TENNESSEE  
37402**

**Request for Bid (RFB) for the City of Chattanooga, Tennessee**

*Proposals will be received at 101 East 11<sup>th</sup> Street, Suite G13,  
Chattanooga, TN 37402 until 2:00 P.M., EST. on September 4, 2019*

**Requisition / Bid No.: R189118 / 305631  
Ordering Dept.: City Wide Services, Public Works  
Buyer & E-mail: Mark McKeel mmckeel@chattanooga.gov**

\*\*\*\*\*

**Items Being Purchased: Tire Disposal & Recycling Services**

\*\*\*\*\*

**\*\*\*REQUEST FOR QUOTES MUST BE RECEIVED\*\*\*  
2:00 P.M., EST on September 4, 2019**

\*\*\*\*\*

**\*\*\*NON-MANDATORY PRE-BID CONFERENCE WILL BE CONDUCTED\*\*\*  
10:00 A.M. EST on August 28, 2019 at Purchasing Conference Room,  
101 East 11<sup>th</sup> Street, Suite G13, Chattanooga, TN 37402**

\*\*\*\*\*

The City of Chattanooga reserves the right to reject any and/or all proposals, waive any informalities in the proposals received, and to accept any proposal which in its opinion may be for the best interest of the City.

The City of Chattanooga will be non-discriminatory in the purchase of all goods and services on the basis of race, color or national origin.

The City's Standard Terms and Conditions may be found on website:  
<http://www.chattanooga.gov/purchasing/standard-terms-and-conditions>

**Note: ALL BIDS MUST BE SIGNED**

All proposals received are subject to the terms and conditions contained herein and as listed in the above referenced website. The undersigned Offeror acknowledges having received, reviewed, and agrees to be bound to these terms and conditions, unless specific written exceptions are otherwise stated.

**PLEASE PROVIDE THE FOLLOWING INFORMATION:**

Company Name: LIBERTY TIRE RECYCLING  
Mailing Address: 1700 TRANSPORT WAY  
City & Zip Code: KNOXVILLE TN 37924  
Phone/Toll Free No.: 404-561-7958  
Fax No.: 678-400-6131  
E-Mail Address: BCRAWFORD@LIBERTYTIRE.COM  
Contact Person: BRYAN CRAWFORD  
Company Title: REGIONAL SALES MANAGER  
Signature: [Handwritten Signature]

# BID SOLICITATION



**City of Chattanooga**  
 101 East 11th Street, Suite G13  
 Chattanooga, TN 37402

**BID OPENING DATE AND TIME:**  
 04-SEP-19 at 2:00 PM

**BID NUMBER: 305631**

**BUYER:**  
**PHONE #:** (423) 643-7230  
**DELIVERY REQUIRED:**

**SEALED BIDS**

Mail or submit two (2) signed copies of bid form to this office in the enclosed envelope. Retain one copy for your file.

**V  
E  
N  
D  
O  
R**

RFQ

**M  
A  
I  
L  
T  
O**

City of Chattanooga  
 101 East 11th Street, Suite G13  
 Chattanooga, TN 37402

Item	Class-Item	Quantity	Unit	Unit Price	Total
Requisition / Bid# No.: 189118 / 305631 Ordering Dept.: City Wide Services, Public Works Buyer: Mark McKeel Phone No.: 423-643-7236					
Items Being Purchased: Tire Disposal & Recycling Services					
<b>ATTACHMENTS:</b> 1. Specification (1 page) 2. Affirmative Action Plan (2 pages) 3. Iran Divestment Act (1 page) 4. No Contact / No Advocacy Notice (1 page) City of Chattanooga (COC) Terms and Conditions posted on Website <a href="http://www.chattanooga.gov/purchasing/standard-terms-and-conditions">http://www.chattanooga.gov/purchasing/standard-terms-and-conditions</a> If you can't download call buyer for a copy.					
<b>NOTE:</b> A Pre-Bid Conference will be held August 28, 2019 at 10:00 AM, at City Hall, Purchasing Conference Room 101 East 11th Street, Suite G13, Chattanooga, TN 37402 Attendance at the Pre-Bid is Preferred.					
This Shall Be A Twelve (12) Month Blanket Contract To Supply Tire Disposal & Recycling Services as needed by agencies of the City of Chattanooga.					
The Contract Term May Be Renewed For An Additional Two (2) Twelve (12) Months Term Under The Same Terms And Conditions By Mutual Agreement. The City Of Chattanooga And The Contractor May Bilaterally Extend The Contract By Providing Written Confirmation Of Agreement By Both Parties At Least 30 Days Prior To The Contract's Current Expiration Date Into Any Successive Term As Provided Herein.					
QUANTITIES ARE ESTIMATES ONLY THE CITY OF CHATTANOOGA SHALL GUARANTEE NO MINIMUM OR MAXIMUM AMOUNT PURCHASED DURING THE LIFETIME OF THE CONTRACT.					
*** BID MUST BE RECEIVED NO LATER THAN *** *** 2:00 PM EST ON SEPTEMBER 4, 2019 ***					
PLEASE SUBMIT BIDS IN DUPLICATE INDICATING BID NUMBER (305631) ON OUTSIDE PACKAGING					
PLEASE DO NOT EMAIL BIDS					
**** Vendor Shall Hold Prices Firm for First (1st) Year of Contract ****					
<b>Price Escalation Clause:</b> If as a result of a general change in prices or discounts, the Contractor has changed prices to all of its customers, the price under this contract may be adjusted accordingly Contractor may be requested to show proof of alleged price changes prior to approval of any price adjustments.					
<b>NOTE:</b> ALL BIDS MUST BE SIGNED All bids received are subject to the terms and conditions contained herein and as listed in the above referenced website. The undersigned Bidder acknowledges					

# BID SOLICITATION



**City of Chattanooga**  
 101 East 11th Street, Suite G13  
 Chattanooga, TN 37402

<b>BID OPENING DATE AND TIME:</b> 04-SEP-19 at 2:00 PM
<b>BID NUMBER:</b> 305631
<b>BUYER:</b> PHONE #: (423) 643-7230 DELIVERY REQUIRED:

**SEALED BIDS**

Mail or submit two (2) signed copies of bid form to this office in the enclosed envelope. Retain one copy for your file.

<b>V E N D O R</b>	RFQ
--	-----

<b>M A I L T O</b>	City of Chattanooga 101 East 11th Street, Suite G13 Chattanooga, TN 37402
--	---

Item	Class-Item	Quantity	Unit	Unit Price	Total
------	------------	----------	------	------------	-------

having received, reviewed, and agrees to be bound to these terms and conditions, unless specific written exceptions are otherwise stated.

Any manufacturer's names, trade names, brand names, or catalog numbers used in the specifications are for the purpose of describing and establishing general quality levels. Such references are not intended to be restrictive. Bids will be considered for any brand which meets or exceeds the quality of the specifications listed for any item.

The City of Chattanooga reserves the right to reject any and/or all bids, waive any informalities in the bids received, and to accept any bid which in its opinion may be for the best interest of the city.

The City of Chattanooga will be non-discriminatory in the purchase of all goods and services on the basis of race, color, or national origin.

\*\*\*\* NOTE \*\*\*\*  
 PLEASE PROVIDE US WITH THE FOLLOWING INFORMATION:

Company Name LIBERTY TIRE RECYCLING  
 Address 1700 TRANS POND WAY  
KNOXVILLE TN 37924  
 Phone/Toll-Free No. 404 561 7958  
 Fax No. 678 400 6131  
 eMail Address BCRAWFORD@LIBERTYTIRE.COM  
 Contact Person's Name BRYAN CRAWFORD  
 Estimated Delivery AS NEEDED

Minority-Owned Business \_\_\_\_\_ Small Business \_\_\_\_\_ Veteran \_\_\_\_\_  
 Minority Woman-Owned Business \_\_\_\_\_ Disabled Veteran \_\_\_\_\_  
 Woman-Owned Business \_\_\_\_\_

\*\*\*\* ALL ITEMS MUST BE QUOTED F O B DESTINATION \*\*\*\*

**NOTE: ALL BIDS RECEIVED ARE SUBJECT TO THE TERMS AND CONDITIONS**

The City is Exempt from all Federal and State Tax  
 Bids will be received at the above mentioned address.

TERMS OF PAYMENT Net 30  
 TELEPHONE NUMBER: 404 561 7958

ALL BIDS MUST BE SIGNED - The undersigned offers the above quoted prices under the conditions contained herein

COMPANY: LIBERTY TIRE RECYCLING  
 SIGNATURE: [Signature]  
 NAME AND TITLE BRYAN CRAWFORD  
REGIONAL SALES MGR.

# BID SOLICITATION



City of Chattanooga  
101 East 11th Street, Suite G13  
Chattanooga, TN 37402

<b>BID OPENING DATE AND TIME:</b> 04-SEP-19 at 2:00 PM  <b>BID NUMBER: 305631</b>
<b>BUYER:</b> PHONE #: (423) 643-7230 <b>DELIVERY REQUIRED:</b>

SEALED BIDS

Mail or submit two (2) signed copies of bid form to this office in the enclosed envelope. Retain one copy for your file.

V  
E  
N  
D  
O  
R

RFQ

M  
A  
I  
L  
T  
O

City of Chattanooga  
101 East 11th Street, Suite G13  
Chattanooga, TN 37402

Item	Class-Item	Quantity	Unit	Unit Price	Total
1	Contract: Disposal of Tires Priced Per Ton	250	Ton	#114.47 PER TON	

NOTE: ALL BIDS RECEIVED ARE SUBJECT TO THE TERMS AND CONDITIONS

The City is Exempt from all Federal and State Tax  
Bids will be received at the above mentioned address

TERMS OF PAYMENT: net 30

TELEPHONE NUMBER: 404 561 7958

ALL BIDS MUST BE SIGNED – The undersigned offers the above quoted prices under the conditions contained herein

COMPANY: LIBERTY TIRE RECYCLING

SIGNATURE: [Signature]

NAME AND TITLE: BRYAN CAMPBELL  
REGIONAL SALES MGR.

## Affirmative Action Plan

The City of Chattanooga is an equal opportunity employer and during the performance of this Contract, the Contractor agrees to abide by the equal opportunity goals of the City of Chattanooga as follows:

1. The Contractor will not discriminate against any employee or applicant for employment because of race, color, religion, sex, national origin, or handicap. The Contractor will take affirmative action to ensure that applicants are employed, and the employees are treated during employment without regard to their race, color, religion, sex, national origin, or handicap. Such action shall include, but not be limited to, the following: employment, upgrading, demotion, or transfer, recruitment or recruitment advertising, layoff or termination, rates of pay, or other forms of compensation, and selection for training, including apprenticeship. The Contractor agrees to post in conspicuous places, available to employees and applicants for employment, notices setting forth the provisions of this nondiscrimination clause.
2. The Contractor will, in all solicitations or advertisements for employees placed by or on behalf of the Contractor, state that all qualified applicants will receive consideration for employment without regard to race, color, religion, sex, national origin, or handicap.
3. The Contractor will send to each labor union or representative of workers with which he/she has a collective bargaining agreement or other contract or understanding, a notice advising the said labor union or workers' representatives of the Contractor's commitments under this section, and shall post copies of the notice in conspicuous places available to employees and applicants for employment.
4. In all construction contracts or subcontracts in excess of \$10,000 to be performed for the City of Chattanooga, any contractor and/or subcontractor is further required to file in duplicate within ten (10) days of being notified that it is the lowest responsible bidder, an affirmative action plan with the EEO Director of the City of Chattanooga. This plan shall state the Contractor's goals for minority and women utilization as a percentage of the work force on this project.
5. This Plan or any attachments thereto shall further provide a list of all employees annotated by job function, race, and sex who are expected to be utilized on this project. This plan or attachment thereto shall further describe the methods by which the Contractor or Subcontractor will utilize to make good faith efforts at providing employment opportunities for minorities and women.

During the term of this contract, the Contractor upon request of the City, will make available for inspection by the City of Chattanooga copies of payroll records, personnel documents and similar records or documents that may be used to verify the Contractor's compliance with these Equal Opportunity provisions.

6. The Contractor will include the portion of the sentence immediately preceding paragraph 1 and the provisions of paragraphs 1 through 6 in every subcontract so that such provisions will be requested of each subcontractor. The Contractor agrees to notify the City of Chattanooga of any subcontractor who refuses or fails to comply with these equal opportunity provisions. Any failure or refusal to comply with these provisions the Contractor and/or Subcontractor shall be a breach of this contract.



---

(Signature of Contractor)

LIBERTY TIRE RECYCLING

BRIAN CRAWFORD - REGIONAL SALES MGR.

---

(Title and Name of Construction Company)

8/26/19

---

(Date)

Chapter No. 817 (HB0261/SB0377). "Iran Divestment Act" enacted.  
Vendor Disclosure and Acknowledgement

By submission of this bid, each bidder and each person signing on behalf of any bidder certifies, and in the case of a joint bid each party thereto certifies as to its own organization, under penalty of perjury, that to the best of its knowledge and belief that each bidder is not on the list created pursuant to § 12-12-106.

(SIGNED)

(PRINTED NAME)

  
BRIAN CRAWFORD

(BUSINESS NAME)

LIBERTY TIRE RECYCLING

(DATE)

8/26/19

For further information, please see website:

[https://www.tn.gov/assets/entities/generalservices/cpo/attachments/List\\_of\\_persons\\_pursuant\\_to\\_Tenn.\\_Code\\_Ann.\\_12-12-106,\\_Iran\\_Divestment\\_Act-July.pdf](https://www.tn.gov/assets/entities/generalservices/cpo/attachments/List_of_persons_pursuant_to_Tenn._Code_Ann._12-12-106,_Iran_Divestment_Act-July.pdf)



**No Contact/No Advocacy Affidavit**

City of Chattanooga  
Purchasing Division

**For Submission with Sealed RFP, RFQ, Sealed Bid Responses:**

State of GA

County of PICKENS

BRYAN CRAWFORD (agent name), being first duly sworn, deposes and says that:

(1) He/She is the owner, partner, officer, representative, or agent of LIBERTY TIRE RECYCLING (business name), the Submitter of the attached sealed solicitation response to Solicitation # R189114 / 305631

(2) BRYAN CRAWFORD (agent name) swears or affirms that the Submitter has taken notice, and will abide by the following No Contact and No Advocacy clauses:

**NO CONTACT POLICY:** After the posting of this solicitation, a potential submitter is prohibited from directly or indirectly contacting any City of Chattanooga representative concerning the subject matter of this solicitation, unless such contact is made with the Purchasing Division.

**NO ADVOCATING POLICY:** To ensure the integrity of the review and evaluation process, companies and/or individuals submitting sealed solicitation responses, as well as those persons and/or companies formally/informally representing such submitters, may not directly or indirectly lobby or advocate to any City of Chattanooga representative.

**Any business entity and/or individual that does not comply with the No Contact and No Advocating policies may be subject to the rejection or disqualification of its solicitation response from consideration.**

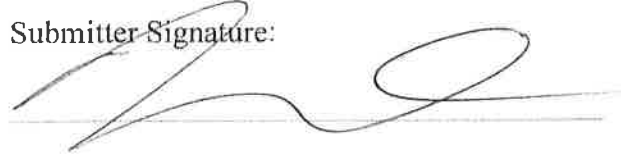
Submitter Signature: 

Printed Name: BRYAN CRAWFORD

Title: \_\_\_\_\_

Subscribed and sworn to before me this 26<sup>th</sup> day of August, 2019.

Notary Public: Stephanie Wright  
My commission expires: Aug. 9th 2021





# City of Chattanooga

Mayor Andy Berke

September 17, 2019

Mr. Justin Holland  
Administrator, Public Works Department  
Waste Resources Division  
1250 Market Street, Suite 2100  
Chattanooga, TN 37402

Subject: 189370/305636- Combustion Total Organic Carbon (TOC)  
Analyzer – Waste Resources – Public Works

Dear Mr. Holland:

The Public Works Department may now seek Council approval to purchase one (1) Combustion Total Organic Carbon (TOC) Analyzer for the Waste Resources Division in the amount of \$44,157.35.

The invitation to bid was sent out to three (3) vendors as well as formally advertised. Bids were received from two (2) vendors. Bids are retained on file in the Purchasing Office for your review upon request.

The low bidder Teledyne Tekmar took exception to the City's standard terms & conditions, and the Department determined that no time is available for consideration of exceptions. I recommend approval of this purchase to Government Scientific Source, Inc., as the best bids meeting specifications for the City of Chattanooga.

Respectfully yours,

Bonnie Woodward  
Director of Purchasing

BW/ab  
Attachments

**Kazmier & Associates, Inc.**  
**210 S. Cherry Street**  
**Lenoir City, TN 37771**

**Government Scientific Source**  
**12351 Sunrise Valley Drive**  
**Reston, VA 20191**

**Teledyne Tekmar**  
**4736 Socialville Foster Road**  
**Mason, OH 45040**

**Bid Tabulation -**

**Bid # 305636 TOC Analyzer**

Item #	Item	Quantity	Government Scientific Source, Inc. Unit Price	Total Price	Teledyne Tekmar Unit Price	Total Price
1	TOC Torch Combustion Part # 15-0300-100	1	\$ 22,711.50	\$ 22,711.50	\$ 20,857.50	\$ 20,857.50
2	Mixing Kit, Torch Part # 15-0431-000	1	\$ 3,166.730	\$ 3,166.73	\$ 3,198.72	\$ 3,198.72
3	System Controller Part # 40-0024-000	1	\$ 1,558.120	\$ 1,558.12	\$ 1,573.86	\$ 1,573.86
4	TOC Installation	1	\$ 2,825.00	\$ 2,825.00	\$ 2,825.00	\$ 2,825.00
5	1 Year Service Agreement	3	\$ 4,632.00	\$ 13,896.00	\$ 4,168.80	\$ 12,506.40
	Shipping		\$0	\$0	\$ 200.00	\$ 200.00

**TOTAL**

**\$44,157.35**

**\$41,161.48**

# BID SOLICITATION



City of Chattanooga  
 101 East 11th Street, Suite G13  
 Chattanooga, TN 37402

**BID OPENING DATE AND TIME:**  
 05-SEP-19 at 2:00 PM

**BID NUMBER:** 305636

**BUYER:**  
**PHONE #:** (423) 643-7230  
**DELIVERY REQUIRED:**

SEALED BIDS

Mail or submit two (2) signed copies of bid form to this office in the enclosed envelope. Retain one copy for your file.

V  
E  
N  
D  
O  
R

RFQ

M  
A  
I  
L  
T  
O

City of Chattanooga  
 101 East 11th Street, Suite G13  
 Chattanooga, TN 37402

Item	Class-Item	Quantity	Unit	Unit Price	Total
------	------------	----------	------	------------	-------

Requisition No : 189370  
 Bid No : 305636  
 Ordering Dept : Waste Resources Division  
 Buyer, Amanda Berkowitz  
 Phone No : (423) 643-7233  
 Email: aberkowitz@chattanooga.gov

Items Being Purchased: Combustion Total Organic Carbon (TOC) Analyzer

ATTACHMENTS:  
 Specifications (2 pgs)  
 Affirmative Action Plan (2 pgs)  
 Iran Divestment Act (1 pg)  
 No Contact / No Advocacy Affidavit  
 City of Chattanooga (COC) Terms and Conditions posted on Website  
<http://www.chattanooga.gov/purchasing/standard-terms-and-conditions>  
 If you can't download call buyer for a copy.

Deadline for Questions: August 29, 2019

\*\*\* BID MUST BE RECEIVED NO LATER THAN \*\*\*  
 \*\*\* 2:00 PM EST ON SEPTEMBER 5, 2019 \*\*\*

NOTE:  
 ALL BIDS MUST BE SIGNED  
 All bids received are subject to the terms and conditions contained herein and as listed in the above referenced website. The undersigned Bidder acknowledges having received, reviewed, and agrees to be bound to these terms and conditions, unless specific written exceptions are otherwise stated.

The City of Chattanooga reserves the right to reject any and/or all bids, waive any informalities in the bids received, and to accept any bid which in its opinion may be for the best interest of the city.

The City of Chattanooga will be non-discriminatory in the purchase of all goods and services on the basis of race, color, or national origin

\*\*\*\* NOTE \*\*\*\*  
 PLEASE PROVIDE US WITH THE FOLLOWING INFORMATION

Company Name Government Scientific Source, Inc.

Address 12351 Sunrise Valley Drive  
Reston, VA 20191

Phone/Toll-Free No 703-880-5020 or 800-248-8030

Fax No 703-935-0299

eMail Address Sales-B@govsci.com

Contact Person's Name Michael Spong

# BID SOLICITATION



City of Chattanooga  
 101 East 11th Street, Suite G13  
 Chattanooga, TN 37402

<b>BID OPENING DATE AND TIME:</b> 05-SEP-19 at 2:00 PM  <b>BID NUMBER: 305636</b>
<b>BUYER:</b> PHONE #: (423) 643-7230 <b>DELIVERY REQUIRED:</b>

**SEALED BIDS**

Mail or submit two (2) signed copies of bid form to this office in the enclosed envelope. Retain one copy for your file.

**V**  
**E**  
**N**  
**D**  
**O**  
**R**

RFQ

**M**  
**A**  
**I**  
**L**  
**T**  
**O**

City of Chattanooga  
 101 East 11th Street, Suite G13  
 Chattanooga, TN 37402

Item	Class-Item	Quantity	Unit	Unit Price	Total
Estimated Delivery	4-6 weeks after receipt of order				
Minority-Owned Business _____ Small Business <input checked="" type="checkbox"/> Veteran _____ Minority Woman-Owned Business _____ Disabled Veteran _____ Woman-Owned Business _____ **** ALL ITEMS MUST BE QUOTED F.O.B. DESTINATION ****					

NOTE: ALL BIDS RECEIVED ARE SUBJECT TO THE TERMS AND CONDITIONS

The City is Exempt from all Federal and State Tax  
 Bids will be received at the above mentioned address.

TERMS OF PAYMENT: NET 30  
 TELEPHONE NUMBER: 703-880-5020

ALL BIDS MUST BE SIGNED - The undersigned offers the above quoted prices under the conditions contained herein.

COMPANY Government Scientific Source, Inc  
 SIGNATURE *Ashley McClelland*  
 NAME AND TITLE Ashley McClelland  
Contract Support Specialist

# BID SOLICITATION



City of Chattanooga  
101 East 11th Street, Suite G13  
Chattanooga, TN 37402

<b>BID OPENING DATE AND TIME:</b> 05-SEP-19 at 2:00 PM
<b>BID NUMBER:</b> 305636
<b>BUYER:</b> <b>PHONE #:</b> (423) 643-7230 <b>DELIVERY REQUIRED:</b>

**SEALED BIDS**

Mail or submit two (2) signed copies of bid form to this office in the enclosed envelope. Retain one copy for your file.

<b>V E N D O R</b>	RFQ
--	-----

<b>M A I L T O</b>	City of Chattanooga 101 East 11th Street, Suite G13 Chattanooga, TN 37402
--	---

Item	Class-Item	Quantity	Unit	Unit Price	Total
1	TOC Torch Combustion (Part No. 15-0300-100)	1	Each	22,711.50	22,711.50
2	Mixing Kit, Torch (Part No. 15-0431-000)	1	Each	3,166.73	3,166.73
3	System Controller (Part No. 40-0024-000)	1	Each	1,558.12	1,558.12
4	TOC Installation	1	Each	2,825.00	2,825.00
5	1-Year Select Service Agreement	3	Year	4,632.00	13,896.00

**NOTE: ALL BIDS RECEIVED ARE SUBJECT TO THE TERMS AND CONDITIONS**

The City is Exempt from all Federal and State Tax.  
Bids will be received at the above mentioned address.

TERMS OF PAYMENT Net 30  
TELEPHONE NUMBER: 703-880-5020

ALL BIDS MUST BE SIGNED – The undersigned offers the above quoted prices under the conditions contained herein.

COMPANY Government Scientific Source, Inc.  
SIGNATURE Ashley McClelland  
NAME AND TITLE Ashley McClelland, Contract Support Specialist

SPECIFICATIONS FOR A  
 COMBUSTION TOTAL ORGANIC CARBON (TOC) ANALYZER  
 FOR  
 MOCCASIN BEND ENVIRONMENTAL LABORATORY  
 CITY OF CHATTANOOGA

Do Not Substitute

The TOC system will be comprised of the following:

Line	Teledyne Tekmar Item #	Description and specifications
1	15-0300-100	<p><b>TORCH, 115V, W/ 40 ML TRAY</b>            TOC Torch Combustion TOC Analyzer PC / Network Driven System 110VAC. Includes Integrated Autosampler with Septum-Piercing Needle, Autosampler Tray for (75) position for 40mL VOA Vials and (4) positions for 125mL bottles for stock solutions, electronic mass flow controller, easy access combustion tube, and intellidilution feature. Package includes TOC Teklink software, installation kit box, reagent bottle, and waste container.</p> <ul style="list-style-type: none"> <li>• Has built-in benchmark diagnostic check - including leak check</li> <li>• Has ability to program and store furnace temperatures to accommodate various methods</li> <li>• Can automatically detect samples that have exceeded the selected calibration range and dilute it to fall within the selected range</li> <li>• Has multiple pre-set application ranges for analytical requirements</li> <li>• Has auto-calibration, eliminating the need for manual standard preparation</li> <li>• Detection Levels:               <ul style="list-style-type: none"> <li>○ Carbon 50ppb to 30,000ppm</li> <li>○ Nitrogen 50ppb to 2,000ppm</li> </ul> </li> <li>• Able to simultaneously analyze for Carbon and Nitrogen</li> <li>• Has easy access for maintenance of combustion tube</li> <li>• Improved catalyst</li> <li>• Built-in autosampler</li> <li>• Increased throughput with ASM Sparge</li> <li>• Has Auto-blanking feature</li> <li>• Has Mass Flow Controller</li> <li>• Has optional vial mixing capabilities</li> <li>• Has optional TN Module</li> </ul>
2	15-0431-100	<p><b>MIXING KIT, TORCH</b>            40mL vial mixing option, includes 75 position mixing tray, mixer assembly, rinse station, and 5 pack of stir bars</p> <p>Mixes the samples for proper analysis. Wastewater samples have high solids content, and mixing is necessary for accurate results.</p>



3 40-0024-000

**SYSTEM CONTROLLER**

Computer workstation compatible with Teledyne Teklink software.  
Capable of controlling the analyzer, compiling data, and preparing reports.

4

TOC Installation – installation at the City’s lab by the manufacturer’s factory-trained engineer.

5

1 Year Select Service Agreement–Torch.

- Free unlimited technical phone support
- Free parts for repairs (excluding consumable parts)
- Free upgrades
- One preventative maintenance visit per year
- 48-hour response time

## Affirmative Action Plan

The City of Chattanooga is an equal opportunity employer and during the performance of this Contract, the Contractor agrees to abide by the equal opportunity goals of the City of Chattanooga as follows:

1. The Contractor will not discriminate against any employee or applicant for employment because of race, color, religion, sex, national origin, or handicap. The Contractor will take affirmative action to ensure that applicants are employed, and the employees are treated during employment without regard to their race, color, religion, sex, national origin, or handicap. Such action shall include, but not be limited to, the following: employment, upgrading, demotion, or transfer, recruitment or recruitment advertising, layoff or termination, rates of pay, or other forms of compensation, and selection for training, including apprenticeship. The Contractor agrees to post in conspicuous places, available to employees and applicants for employment, notices setting forth the provisions of this nondiscrimination clause.
2. The Contractor will, in all solicitations or advertisements for employees placed by or on behalf of the Contractor, state that all qualified applicants will receive consideration for employment without regard to race, color, religion, sex, national origin, or handicap.
3. The Contractor will send to each labor union or representative of workers with which he/she has a collective bargaining agreement or other contract or understanding, a notice advising the said labor union or workers' representatives of the Contractor's commitments under this section, and shall post copies of the notice in conspicuous places available to employees and applicants for employment.
4. During the term of this contract the following non-discriminatory hiring practices shall be employed to provide employment opportunities for minorities and women:
  - a. All help wanted ads placed in newspapers or other publications shall contain the phrase "Equal Employment Opportunity Employer."
  - b. Seek and maintain contracts with minority groups and human relations organizations as available.

- c. Encourage present employees to refer qualified minority group and female applicants for employment opportunities
  - d. Use only recruitment sources which state in writing that they practice equal opportunity. Advise all recruitment sources that qualified minority group members and women will be sought for consideration for all positions when vacancies occur.
5. Minority statistics are subject to audit by City of Chattanooga staff or other governmental agency.
6. The Contractor agrees to notify the City of Chattanooga of any claim or investigation by State or Federal agencies as to discrimination.

Ashley McClelland  
(Signature of Contractor)

Contract Support Specialist , Government Scientific Source, Inc  
(Title and Name of Company)

8-26-2019  
(Date)

Chapter No. 817 (HB0261/SB0377).  
"Iran Divestment Act" enacted.  
Vendor Disclosure and Acknowledgement

By submission of this bid, each proposer and each person signing on behalf of any proposer certifies, and in the case of a joint bid each party thereto certifies as to its own organization, under penalty of perjury, that to the best of its knowledge and belief that each proposer is not on the list created pursuant to § 12-12-106.

(SIGNED)

Ashley McClelland

(PRINTED NAME)

Ashley McClelland

(BUSINESS NAME)

Government Scientific Source, Inc

(DATE)

8/26/2019

**No Contact/No Advocacy Affidavit**

City of Chattanooga  
Purchasing Division

**For Submission with Sealed RFP, RFQ, Sealed Bid Responses:**

State of Virginia

County of Fairfax

Ashley McClelland (agent name), being first duly sworn, deposes and says that:

(1) He/She is the owner, partner, officer, representative, or agent of Government Scientific Source, Inc (business name), the Submitter of the attached sealed solicitation response to Solicitation # RFB 305636;

(2) Ashley McClelland (agent name) swears or affirms that the Submitter has taken notice, and will abide by the following No Contact and No Advocacy clauses:

**NO CONTACT POLICY:** After the posting of this solicitation, a potential submitter is prohibited from directly or indirectly contacting any City of Chattanooga representative concerning the subject matter of this solicitation, unless such contact is made with the Purchasing Division.

**NO ADVOCATING POLICY:** To ensure the integrity of the review and evaluation process, companies and/or individuals submitting sealed solicitation responses, as well as those persons and/or companies formally/informally representing such submitters, may not directly or indirectly lobby or advocate to any City of Chattanooga representative.

**Any business entity and/or individual that does not comply with the No Contact and No Advocating policies may be subject to the rejection or disqualification of its solicitation response from consideration.**

Submitter Signature:

Ashley McClelland

Printed Name:

Ashley McClelland

Title: Contract Support Specialist

Subscribed and sworn to before me this 26 day of August, 2019.

Notary Public:

Ann deWitt Toll

My commission expires: September 30, 2021

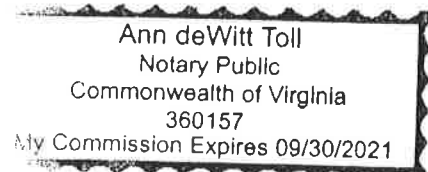



# City of Chattanooga

Mayor Andy Berke

September 17, 2019

Mr. Justin Holland  
Administrator, Public Works Department  
Facilities Management Division  
1250 Market Street, Suite 2100  
Chattanooga, TN 37402

Subject: 184631 / 305548 – Floor Cleaning Services for City Hall Campus –  
Facilities Management Division – Public Works Department

Dear Mr. Holland:

The Public Works Department may now seek Council approval to issue a blanket contract for Floor Cleaning Services for City Hall Campus for the Facilities Management Division. The contract will be for twelve (12) months with the option to renew for two (2) additional twelve (12) month terms. The Department's estimated annual expenditure for this contract is \$325,000.

The invitation to bid was sent to seven (7) vendors as well as formally advertised. Bids were received from four (4) vendors shown below. Bids are retained on file in the Purchasing Office for your review upon request.

Vendors

Jani-King of Chattanooga  
Clean Right Solutions, LLC

Certified Maintenance Service Inc  
Metro Janitorial Service, Inc

Page 2

**Floor Cleaning Services for City Hall Campus**

I recommend awarding the blanket contract for Floor Cleaning Services for City Hall Campus to Jani-King of Chattanooga, 7610 Hamilton Park Drive, Suites 3 & 4, Chattanooga, TN 37421, as the best complete bid meeting specifications for the City of Chattanooga. Metro Janitorial Service, Inc was the apparent low bidder, but due to past performance, Facilities Management Division could not award to this vendor. Therefore, Facilities Management Division recommends awarding the contract to Jani-King of Chattanooga, who offers the best responsive and responsible bid which meets the specifications for the City of Chattanooga.

Respectfully yours,



**Bonnie Woodward**  
Director of Purchasing

BW/mlm

Attachments

Requisition:	184631		UOM	Jan-King of Chattanooga			Certified Maintenance Service Inc			Clean Right Solutions, LLC			Metro Janitorial Service, Inc		
	Bid #:	305548		Unit Price	Qty.	Extended Price	Unit Price	Qty.	Extended Price	Unit Price	Qty.	Extended Price	Unit Price	Qty.	Extended Price
Description:	Floor Cleaning & Related Services for City Hall Campus			Jan-King of Chattanooga			Certified Maintenance Service Inc			Clean Right Solutions, LLC			Metro Janitorial Service, Inc		
Item #	Item Description	UOM	Unit Price	Qty.	Extended Price	Unit Price	Qty.	Extended Price	Unit Price	Qty.	Extended Price	Unit Price	Qty.	Extended Price	
A	Initial Cleaning Tasks	Once	\$ -	1	\$ -	\$ -	1	\$ -	\$ 81,600.00	1	\$ 81,600.00	\$ 29,433.28	1	\$ 29,433.28	
B	Bessie Smith Cultural Center	Annual	\$ 29,919.00	1	\$ 29,919.00	\$ 41,940.00	1	\$ 41,940.00	\$ 74,100.00	1	\$ 74,100.00	\$ 19,534.20	1	\$ 19,534.20	
C	City Council Building	Annual	\$ 15,787.00	1	\$ 15,787.00	\$ 21,540.00	1	\$ 21,540.00	\$ 74,100.00	1	\$ 74,100.00	\$ 10,298.84	1	\$ 10,298.84	
D	City Hall	Annual	\$ 74,256.00	1	\$ 74,256.00	\$ 101,940.00	1	\$ 101,940.00	\$ 74,100.00	1	\$ 74,100.00	\$ 41,594.40	1	\$ 41,594.40	
E	City Hall Annex	Annual	\$ 43,962.00	1	\$ 43,962.00	\$ 59,940.00	1	\$ 59,940.00	\$ 74,100.00	1	\$ 74,100.00	\$ 24,609.60	1	\$ 24,609.60	
F	Development Resource Center	Annual	\$ 106,151.00	1	\$ 106,151.00	\$ 143,940.00	1	\$ 143,940.00	\$ 148,200.00	1	\$ 148,200.00	\$ 69,384.00	1	\$ 69,384.00	
G	Facilities Management Building	Annual	\$ 9,458.00	1	\$ 9,458.00	\$ 12,000.00	1	\$ 12,000.00	\$ 74,100.00	1	\$ 74,100.00	\$ 8,556.00	1	\$ 8,556.00	
H	Lindsey Street Building	Annual	\$ 9,666.00	1	\$ 9,666.00	\$ 12,000.00	1	\$ 12,000.00	\$ 74,100.00	1	\$ 74,100.00	\$ 6,283.20	1	\$ 6,283.20	
I	WellAdvantage Health & Wellness Center	Annual	\$ 26,427.00	1	\$ 26,427.00	\$ 35,940.00	1	\$ 35,940.00	\$ 111,150.00	1	\$ 111,150.00	\$ 17,241.84	1	\$ 17,241.84	
<b>Totals:</b>	<b>First-Year Total Annual Cost of Services (A-G)</b>				<b>\$ 315,626.00</b>			<b>\$ 429,240.00</b>			<b>\$ 785,550.00</b>			<b>\$ 226,935.36</b>	
<b>Totals:</b>	<b>Second-Year Total Annual Cost of Services (B-G)</b>				<b>\$ 315,626.00</b>			<b>\$ 429,240.00</b>			<b>\$ 703,950.00</b>			<b>\$ 197,502.08</b>	



**Certified Maintenance Service,  
Inc. (CMS, Inc.)  
1504 Merrill Street  
Chattanooga, TN 37412**

**Metro Janitorial Services Inc.  
8115 Snowhill Road  
Ooltewah, TN 37363**

**Cleaning Solutions, LLC  
5600 Brained Road, Suite W-6  
Eastgate Town Center  
Chattanooga, TN 37411**

**ABM Industry Group, LLC  
4295 Cromwell Road, Suite 412  
Chattanooga, TN 37421**

**Jani-King of Chattanooga  
6005 Century Oaks Drive  
Suite 101  
Chattanooga, TN 37416**

**Reliable Building Solutions, Inc  
6232 Airpark Drive  
Chattanooga, TN 37421**

**Single Moms Cleaning Services,  
LLC  
4804 Waverly Court  
Ooltewah, TN 37363**



**CITY OF CHATTANOOGA**  
**Independent Contractor Services Standard Form Agreement**

This INDEPENDENT CONTRACTOR SERVICES AGREEMENT (hereafter "Agreement") is hereby made and entered into this \_\_\_\_\_ day of \_\_\_\_\_ 2019 by and between AUTUMN WIND FRANCHISING, INC. d/b/a JANI-KING OF CHATTANOOGA, a Tennessee corporation with its office located at 7610 Hamilton Park Drive, Suites 3 & 4, Chattanooga, TN 37421 ("Jani-King" or "Contractor") and the CITY OF CHATTANOOGA, a Tennessee municipal corporation with offices at City Hall, 101 E. 11th Street, Chattanooga, TN 37402 ("City" or "Client"), each individually referred to herein as a "Party" and collectively as the "Parties". This Agreement shall be effective as of the date signed by the City's authorized signatory ("Effective Date").

This Agreement is prepared by the City of Chattanooga and sets forth the terms by which the stated Contractor shall perform the services identified in the Scope of Services attached hereto as **Exhibit A** and incorporated herein by reference.

In consideration of the faithful performance of the terms, covenants, and conditions and the mutual obligations as set forth herein, the City and Contractor agree as follows:

1. **Term.** The Term of this Agreement shall be begin on the Effective Date and end on June 30, 2020.
2. **Independent Contractor.** Subject to the terms and conditions of this Agreement, the City hereby engages the Contractor as an independent contractor to perform the services set forth herein, and the Contractor hereby accepts such engagement. Contractor is not an employee of the City. The Contractor's relationship to the City shall be that of independent contractor. The Contractor shall not represent or hold himself out to be an employee of City. The Contractor is not eligible to receive any health, medical, wellness or fringe benefits from the City.
3. **Scope of Services.**
  - a. City engages the Contractor to provide floor cleaning and related services (the "Services") for the purpose of keeping its premises cleaned as set forth in the Cleaning Schedule attached hereto as **Exhibit A** and incorporated herein by reference.
  - b. Contractor warrants that the Services will be performed in a professional, efficient, and diligent manner consistent with generally accepted industry standards and with the level of competency and standard of care normally observed by a person practicing in Contractor's profession. If City determines that any of the Services are not performed in accordance with such level of competency and standard of care, City, in its sole discretion, shall have the right to do any or all of the following: (a) require Contractor to meet with City to review the quality of the Services provided and resolve matters of concern; (b) require Contractor to repeat any substandard Services at no additional charge until it is satisfactory; (c) terminate this Agreement

pursuant to Section 12 below; or (d) pursue any and all other remedies at law or in equity.

- c. The premises making up the working area under this Agreement will be hereafter referred to as the "Named Areas", which are further defined in **Exhibit A**.
- d. Jani-King agrees to service Named Areas as scheduled five (5) times per week.
- e. Jani-King agrees to furnish all equipment and tools necessary for the performance of the Services under this Agreement. Client warrants that the Named Areas are free of asbestos, hazardous materials and hazardous waste materials. Subject to the Tennessee Governmental Tort Liability Act, T.C.A. § 29-20-101 *et seq.*, Client hereby agrees to hold Jani-King and its authorized franchise owners harmless from any and all liability resulting from any Jani-King personnel or authorized franchise owner or its personnel's exposure to such hazardous or harmful materials.

4. **Compensation Terms.**

- a. The Client shall compensate Jani-King for the Services rendered pursuant to this Agreement as set forth in the Pricing Schedule, attached hereto as **Exhibit B** and incorporated herein by reference.
- b. It is understood and agreed that City will not withhold any amount for payment of taxes from the compensation of the Contractor.
- c. The City's delivered payment terms are payment within thirty (30) days except where the law provides otherwise. Contractor shall invoice the City for Services performed. In no event will payment be made prior to receipt of an original invoice. The City is not liable for delays in payment caused by failure of the Contractor to send invoices to the address referenced herein.
- d. Client agrees that all payments due to Jani-King will be properly credited only when delivered to the following address:

Jani-King of Chattanooga  
Attn: Julie Graci  
609 Reliability Circle  
Knoxville, TN 37932  
(865) 671-5464  
jgraci@jkccs.com

- e. Credits for holidays were pre-determined and given as part of the monthly charge herein, and no other adjustments will be made for those holidays.

- f. From time to time, as the Parties may agree, the amount to be paid by Client may be increased or decreased to reflect an increase or decrease in the area of space serviced and the kind, amount or frequency of service to be rendered. Such modifications shall be binding only if in writing, signed by both Parties. In the event mutual agreement relating to frequency of service, type of service, space serviced or amount to be paid cannot be reached, the frequency of service, type of service, space serviced or amount to be paid shall remain unchanged.
- g. It is hereby agreed that the total minimum sum stated in the Pricing Schedule may be increased annually by Contractor, with written notice to Client, by a percentage amount not to exceed the annual increase of the Consumer Price Index as most recently published in the Wall Street Journal.
- h. In the event payment for services is not received within thirty (30) days from the date Jani-King sends an invoice to the Client, Jani-King may, after good faith consultation with the Client, suspend services to Client until such payment is received. Suspension of services by Jani-King under this section shall not deprive Jani-King of any of its remedies or actions against Client for past or future payments due under this Agreement, nor shall the bringing of any action for payment of services or other rights contained herein be construed as a waiver of any Jani-King rights.

5. **Supervision of the Work.**

- a. It is expressly agreed that Contractor will select and designate all personnel to perform its obligations under this Agreement. Contractor shall supervise and direct the Services described on **Exhibit A**, using Contractor's best skill and attention as approved by the City. Contractor shall be solely responsible for all methods, techniques, sequences and procedures, and shall coordinate all portions of the Services provided hereunder. City will deal only through Contractor, who shall be responsible for the proper execution of the Services.
- b. Any subcontractor relationships or assignment not identified herein or in **Exhibit A** as part of this Agreement, must first be approved by City.
- c. A subcontractor ("Subcontractor") is a person or organization that has a direct contract with Contractor to perform any of the Services. Contractor agrees that it is as fully responsible to City for the acts and omissions of Subcontractors and of persons either directly or indirectly employed by Contractor as it is for the acts and omissions of persons directly employed by it. Nothing contained in this Agreement or any other document associated with the performance of the Services shall create any contractual relation between any Subcontractor and City.

- d. Contractor shall assign only competent personnel to perform any portion of the Services. If at any time City, in its sole discretion, desires the removal of any person or persons assigned by Contractor to perform the Services, Contractor shall remove such person or persons immediately upon receiving written notice from City. If any person is identified in this Agreement (or any attachment hereto), Contractor shall not remove, replace, substitute, or otherwise change any key personnel without the prior written consent of City.
  - e. Contractor shall be responsible to City for the acts and omissions of Contractor's employees, subcontractors, and their agents and employees, and any other persons performing any of the Services under a contract with Contractor.
  - f. Contractor agrees to bind every Subcontractor and every Subcontractor agrees to be bound by the terms of this Agreement as to that portion of the Services performed by Subcontractor, unless specifically noted to the contrary in a subcontract approved in writing by City. Subcontractor agrees to be bound to the Contractor by the terms of this Agreement and to assume toward Contractor all of the obligations and responsibilities that the Contractor assumes toward City. Contractor agrees to be bound to the Subcontractor by all of the obligations that City assumes to Contractor under this Agreement as to the portion of the Services performed by Subcontractor.
6. **Insurance.** Contractor shall purchase and maintain during the life of this Agreement, insurance coverage which will satisfactorily insure Contractor against claims and liabilities which arise because of the execution of this Agreement, with the minimum insurance coverage as follows:
- a. Commercial General Liability Insurance, with a limit of \$1,000,000 for each occurrence and \$2,000,000 in the general aggregate.
  - b. Automobile Liability Insurance, with a limit of \$1,000,000 for each accident, combined single limit for bodily injury and property damage.
  - c. Worker's Compensation Insurance and Employer's Liability Insurance, in accordance with statutory requirements, with a limit of \$500,000 for each accident.
  - d. Professional Liability Insurance, with a limit of \$1,000,000 for each claim and aggregate.

Contractor shall not begin work under this Agreement until a Certificate of Insurance has been submitted to the City showing proof that Contractor has obtained the necessary insurance coverage. If any of the above cited policies expire during the life of this Agreement, it is the Contractor's responsibility to forward renewal Certificates within ten (10) days after the renewal

date containing all the aforementioned insurance provisions. Certificates must specifically cite the following provisions:

- i. City of Chattanooga, its agents, representatives, officers, directors, officials and employees must be named an Additional Insured under the following policies:
  - a) Commercial General Liability
  - b) Auto Liability
- ii. Contractor's insurance must be primary insurance as respects performance of subject contract.
- iii. All policies, except Professional Liability Insurance, if applicable, waives rights of recovery (subrogation) against City of Chattanooga, its agents, representatives, officers, directors, officials and employees for any claims arising out of work or Services performed by Contractor under this Agreement.

7. **Indemnification.** Contractor must defend, indemnify and hold harmless the City against all damages, claims or liabilities and expenses (including attorney's fees) arising out of or resulting in any way from the goods or services purchased, or from any act or omission of Contractor, its agents, employees or subcontractors. Additionally, Contractor shall defend, indemnify and hold harmless City from and against any and all third party claims and liabilities (including, without limitation, reasonable attorneys' fees and costs), regardless of the form of action, arising out of or in connection with a claim that the Services or Software, when used within the scope of this Agreement, infringes, violates or misappropriates a valid third party patent, copyright or other proprietary right, provided that Contractor is notified promptly in writing of the action and Contractor is given the option, at its expense, to control the action and all requested reasonable assistance to defend the same.

8. **Confidentiality.** Contractor must consider all information furnished by City to be confidential and not disclose any information to any other person, or use the information itself for any purpose other than performing this Agreement, unless Contractor obtains written permission from City to do so. This paragraph applies to drawings, specifications, or other documents prepared by Contractor for City in connection with this Agreement. Contractor must not advertise or publish the fact that City has contracted to purchase goods from Contractor, nor is any information relating to the order to be disclosed without City's written permission. No commercial, financial or technical information disclosed in any manner or at any time by Contractor to City is to be considered secret or confidential, unless otherwise agreed in writing, and Contractor has no rights against City with respect to this information except any rights as may exist under patent laws. Contractor recognizes that City's employees have no authority to accept any information in confidence.

9. **Performance by Contractor.**

- a. **Conduct on City's Premises** -- The Services shall be performed with the City's full cooperation, on the premises of City or remotely. Contractor agrees, while working on City's premises, to observe City's rules and policies relating to the security thereof, access to or use of all or part of the City's premises and any of City's property, including proprietary or confidential information. Contractor agrees that when it is working on City's premises, its personnel shall observe City's administrative and ethics codes relating to the security, access or use of all or part of City's premises and any of City's property, including proprietary or confidential information.
- b. **Inquiries by City** -- Contractor shall respond expeditiously to any inquiries pertaining to this Agreement from City.
- c. **Coordination of Services** -- Contractor shall schedule work hours as needed to coordinate Services with City staff and external parties.

10. **Records and Retention Audit.** The term "Contractor" is used interchangeably to describe signatories to contracts, grants, and agreements with the City and applies to reflect the relationship with the City (Engineer, Contractor, Licensee, Supplier, Vendor, Contractor, Grant Recipient, etc.).

- a. All records relating in any manner whatsoever to the Services, or any designated portion thereof, which are in the possession of the Contractor, or any of the Contractor's independent contractors, associates, and/or subcontractors, shall be made available for inspection and copying upon written request to the City. Additionally, said records shall be made available upon request by the City to any state, federal or other regulatory authorities and any such authority may review, inspect and copy such records. Said records include, but are not limited to, all plans, specifications, submittals, correspondence, minutes, memoranda, tape recordings, videos, or other writings or things which document the Services. Said records expressly include those documents reflecting the time expended by the Contractor and its personnel to perform the obligations of this Agreement, and the records of expenses incurred by the Contractor in its performance under said Agreement. The Contractor shall maintain and protect these records for no less than **seven (7) years** after the completion of the Services, or for any longer period of time as may be required by applicable law, good professional practice, and upon notice during the pendency of any claims or litigation arising from the Services.
- b. The City, or its assigns, may audit all financial and related records (including digital) associated with the terms of the contract or agreement, including timesheets, reimbursable out of pocket expenses, materials, goods and equipment

claimed by the Contractor. The City may further audit any of the Contractor's records to conduct performance audits (to identify waste and abuse or to determine efficiency and effectiveness of the contract or agreement), or to identify conflicts of interest.

- c. The Contractor shall at all times during the term of the contract or agreement, and for a period of seven (7) years after the end of the contract, keep and maintain records of the work performed pursuant to this contract or agreement. This shall include proper records of quotations, contracts, correspondence, invoices, vouchers, timesheets, and other documents that support actions taken by the Contractor. Documents shall be maintained by the Contractor, which are necessary to clearly reflect all work and actions taken. All such records shall be maintained in accordance with general accepted accounting principles. The Contractor shall, at its own expense, make such records available for inspection and audit (including copies and extracts of records as required) by the City at all reasonable times and without prior notice.
- d. The obligations of this Section shall be explicitly included in any subcontracts or agreements formed between the Contractor and any subcontractors or suppliers of goods or non-professional services to the extent that those subcontracts or agreements relate to fulfillment of the Contractor's obligations to the City.
- e. Costs of any audits conducted under the authority of this section and not addressed elsewhere will be borne by the City, unless the audit identifies significant findings that would benefit the City. The Contractor will reimburse the City for the total costs of an audit that identifies significant findings that would benefit the City.
- f. This Section shall not be construed to limit, revoke, or abridge any other rights, powers, or obligations relating to audit which the City may have by Federal, State, or Municipal law, whether those rights, powers, or obligations are express or implied.

11. **Termination for Convenience.** Either Party reserves the right to terminate this Agreement or any part of this Agreement at its sole convenience with no less than thirty (30) days written notice prior to the anniversary date of the Agreement. If timely notice is given for termination, this Agreement shall expire at midnight on the anniversary date. In the event of termination, Contractor must immediately stop all work and immediately cause any of its suppliers or subcontractors to cease any further work. Contractor will not be paid for any work done after receipt of the notice of termination, nor for any costs incurred by Contractor's suppliers or subcontractors which Contractor could reasonably have avoided.



12. **Termination for Cause.**

- a. City may also terminate this Agreement, or any part of this Agreement, with seven (7) days written notice for cause in the event of any default by Contractor. Non-performance, which is defined as the failure, neglect, or refusal to perform the terms and conditions of this Agreement or the Services outlined in the Cleaning Schedule, and/or failure to provide City, upon request, with adequate assurances of future performance are all causes allowing City to cancel this Agreement for cause.
- b. Before any termination for cause is effective, the City must give Jani-King written notice specifying in detail the nature of any defect or failure in performance. Upon the effective date of the receipt of notice of potential termination for cause, Jani-King, at its election, shall have thirty (30) days in which to cure the defect in performance to the reasonable satisfaction of Client.
- c. In the event of cancellation for cause, City is not liable to Contractor for any amount, and Contractor is liable to City for any and all damages sustained by reason of the default which gave rise to the cancellation. If it should be determined that City has improperly cancelled this contract for a default, the cancellation is considered a termination for convenience.

13. **Dispute Resolution.** Claims, disputes, or other matters in question between the Parties to this Agreement arising out of or relating to this Agreement, or breach thereof, shall be subject to mediation in Chattanooga, Tennessee, in accordance with the following provisions:

- a. The mediation shall be conducted by a mediator mutually acceptable to both Parties.
- b. The Parties agree to share equally in the expense of the mediation.
- c. Such mediation may include the Contractor or any other person or entity who may be affected by the subject matter of the dispute.
- d. Unless the Parties agree otherwise, mediation shall be a condition precedent to the exercise of any legal remedy other than a proceeding seeking an immediate injunction or restraining order to protect the rights of a Party pending litigation. Notwithstanding the issuance of an injunction or restraining order, or the refusal of a court to issue such an order, the dispute shall continue to be subject to mediation.

14. **Delay in Performance.** Neither City nor Contractor shall be considered in default of the Agreement for delays in performance caused by circumstances beyond the reasonable control of

the nonconforming Party. For purposes of this Agreement, such circumstances include abnormal weather conditions; floods; earthquakes; fire; epidemics; war, riots, or other civil disturbances; sabotage; judicial restraint; discovery of unanticipated hazardous wastes; and inability to procure permits, licenses, or authorizations from any local, state, or federal agency for any of the supplies, materials, accesses, or services required to be provided by either City or Contractor under this Agreement. Should such circumstances occur, the nonconforming Party shall, within a reasonable time of being prevented from performing, give written notice to the other party describing the circumstances preventing continued performance and the efforts being made to resume performance of the Agreement. If the Contractor is delayed in the performance of the services for more than three hundred sixty-five (365) calendar days, either by the City or circumstances beyond his control, an equitable adjustment to the contract amount can be made to compensate for additional costs incurred.

For delays in performance by Contractor caused by circumstances which are within its control, such delays shall be documented and presented to the Purchasing Department at the conclusion of the Services and acknowledged by both City and Contractor. Completed form shall be retained by City for a period of seven years and reviewed prior to Contractor selection for future City projects. In the event Contractor is delayed in the performance of Services because of delays caused by City, Contractor shall have no claim against City for damages or contract adjustment other than an extension of time.

15. **Notice.** Any notice required or permitted to be given to any party to this Agreement shall be given in writing and shall be delivered personally or sent by United States mail postage prepaid or by a nationally recognized overnight carrier, or sent by e-mail addressed to the Parties as set forth below:

If to Contractor:

Jani-King of Chattanooga  
Attn: Josh Sherwood  
Regional Director  
7610 Hamilton Park Drive, Suites 3 & 4  
Chattanooga, TN 37421  
(423) 648-3101  
jsherwood@jkccs.com

If to City:

City of Chattanooga  
Department of Public Works  
Attn: Administration  
1250 Market Street  
Chattanooga, TN 37402  
(423) 643-6311

With Copy to:

City of Chattanooga  
Office of the City Attorney  
100 E. 11<sup>th</sup> Street, Suite 200  
Chattanooga, TN 37402  
(423) 643-8250

Either party may alter the address to which communications or copies are to be sent by giving notice of the change of address to the other party.

16. **Waiver.** A waiver by either City or Contractor of any breach of this Agreement shall be in writing. City's failure to insist on performance of any of the terms or conditions of this Agreement or to exercise any right or privilege, or City's waiver of any breach does not waive any other terms, conditions, or privileges, whether of the same or similar type.
17. **Severability.** The invalidity, illegality, or unenforceability of any provision of this Agreement or the occurrence of any event rendering any portion or provision of this Agreement void shall in no way affect the validity or enforceability of any other portion or provision of this Agreement. Any void provision shall be deemed severed from this Agreement, and the balance of this Agreement shall be construed and enforced as if this Agreement did not contain the particular portion or provision held to be void. The parties further agree to amend this Agreement to replace any stricken provision with a valid provision that comes as close as possible to the intent of the stricken provision. The provisions of this Section 19 shall not prevent this entire Agreement from being void should a provision which is of the essence of this Agreement be determined void.
18. **Governing Law.** This Agreement shall be governed by the laws of the State of Tennessee and the Codes of the City of Chattanooga.
19. **Entire Agreement.** This Agreement represents the entire and integrated agreement between City and Contractor. All prior and contemporaneous communications, representations, and agreements by Contractor, whether oral or written, relating to the subject matter of this Agreement, are hereby incorporated into and shall become a part of this Agreement.
20. **Successors and Assigns.** City and Contractor each binds itself and its directors, officers, partners, successors, executors, administrators, assigns, and legal representatives to the other party of this Agreement and to the directors, officers, partners, successors, executors, administrators, assigns, and legal representatives of such other party in respect to all provisions of this Agreement.
21. **Assignment.** Neither City nor Contractor shall assign any rights or duties under this Agreement without the prior written consent of the other Party. Unless otherwise stated in the written consent to an assignment, no assignment will release or discharge the assignor from any obligation under this Agreement. Nothing contained in this Article shall prevent Contractor from employing independent contractors, associates, and subcontractors to assist in the performance of the Services; however, other agreements to the contrary notwithstanding, in the event Contractor employs independent contractors, associates, and subcontractors to assist in performance of the Services, Contractor shall be solely responsible for the negligent performance of the independent contractors, associates, and subcontractors so employed.

22. **Third Party Rights.** Nothing in this Agreement shall be construed to give any rights or benefits to anyone other than City and Contractor.
23. **Relationship of Parties.** Nothing contained herein shall be construed to hold or to make the City a partner, joint venturer, or associate of Contractor, nor shall either party be deemed the agent of the other, it being expressly understood and agreed that the relationship between the Parties is and shall at all times remain contractual as provided by the terms and conditions of this Agreement.
24. **Amendment.** This Agreement may only be amended or modified in writing signed by the Parties hereto.
25. **Non-Disclosure.** Contractor agrees not to disclose or to permit disclosure of any information designated by the City as confidential, except to the Contractor's employees and independent Contractors, associates, and subcontractors who require such information to perform the services specified in this agreement.
26. **Non-Discrimination.** Contractor agrees to comply with all federal, state, and local non-discrimination laws and regulations. Contractor agrees not to discriminate against any participant in this Agreement on the basis of race, color, religion, sex, age or national origin. Contractor further agrees to comply with all federal, state and local laws regarding treatment and accommodations for individuals with disabilities.
27. **Drug Free Workforce.** Contractor certifies that it will provide a drug-free workplace and agrees to comply with the applicable requirements of the Drug-Free Workplace Act of 1988.
28. **Federal or State Funding.** In the event that the project is funded in whole or in part by Federal or State grants, Contractor agrees to abide by all applicable Federal and State laws, regulations, grant conditions and procedures.
29. **Compliance with Laws.** The City has entered into this Agreement with Contractor relying on its knowledge and expertise to provide the Services contracted for. As part of that reliance, Contractor represents that he knows and understands the relevant and applicable federal and state laws that apply to the Services provided through this contract, and agrees to comply with these relevant and applicable federal and state laws.

The Contractor understands and acknowledges the applicability to it of the American with Disabilities Act, the Immigration Reform and Control Act of 1986, and the Drug Free Workplace Act of 1988.

[SIGNATURE PAGE TO FOLLOW]

**City of Chattanooga Independent Contractor Services Standard Form Agreement**

IN WITNESS WHEREOF, the Parties, through their authorized representatives, have executed this Agreement which shall become effective as of the Effective Date stated herein.

Attest:	CITY OF CHATTANOOGA, TENNESSEE
	By:
	Printed Name:
	Title:
	Date:

Attest:	CONTRACTOR
	By: 
	Printed Name: Josh Sherwood
	Title: Regional Director
	Date: 9-5-19

**ATTACHMENTS: Exhibit A Scope of Services; Exhibit B: Fee Schedule**

**EXHIBIT A**  
**SCOPE OF SERVICES**  
**Pg. 1**

**INITIAL CLEANING:** Upon inspection of the City of Chattanooga facilities specified in page 3 of Exhibit A, the contractor shall determine that additional up-front work is required to bring the facilities up to a standard and maintainable condition. This initial cleaning shall be a lump-sum amount for all materials, equipment and labor required and shall be applicable only at the beginning of the initial term of the contract.

**DAILY: (Five (5) days per week- Monday through Friday)**

1) BARE FLOOR CARE:

- a) Bare floors, base moldings, and grout shall be clean and free of debris including but not limited to dirt, water streaks, mop marks, string, gum, tar, and other foreign matter. The floors shall maintain their natural luster and not have a dull appearance.
- b) Bare floors shall be swept and/or dust mopped with dust control treated mops.
- c) Wet mopping of bare floors shall be cleaned using disinfectant cleaner(s). Surfaces, baseboards, and corners shall be clean and dry.
- d) Walls, baseboards, and other surfaces shall be free of splashing and markings from the equipment. There shall be no visible buildup of finish in corners or crevices.
- e) Mops and cleaning rags shall be cleaned and sanitized before and after each day of use. Mops and cleaning rags used in restrooms shall not be used to clean any other areas.
- f) Spot mop all tile floors and remove all spots caused by spillages.
- g) Main lobby floors shall be spray buffed as needed followed by dust mopping with dust control treated mop.

2) CARPETS AND RUGS:

- a) Vacuuming: Carpet surfaces are to be free of dirt, dust, and other debris. Vacuuming shall be done at a frequency that will protect the integrity of the carpet and prolong wear. HEPA filtration vacuums are required.
- b) Carpet edges and baseboards shall be swept or vacuumed with a wand attachment to remove particles from edges.
- c) Spot Cleaning: Carpet surfaces shall be free of removable spots, soiled traffic patterns, dirt, dust, debris, gum, and crusted materials.

3) TILE FLOORS, RESTROOMS, SHOWERS:

- a) All floors shall be thoroughly swept and wet mopped with anti-bacterial detergent and rinsed thoroughly.
- b) Fittings and supply pipes will be kept clean any cleaning materials, splashes, or spillage caused by the contractor.

**EXHIBIT A**  
**SCOPE OF SERVICES**

**Pg. 2**

4) MISCELLANEOUS

- a) Decorative private offices and reception areas shall be given special attention in keeping with any special floor finishes.
- b) Keep all baseboards, doors, door kick-plates and furniture bases clean.
- c) Sweep all outside entrances.
- d) Clean and organize any designated storage areas.
- e) Shut off all interior lights.
- f) Close and lock all designated interior doors.
- g) Ensure that all exterior doors are properly closed and locked.
- h) Notify police of any incidents or suspicious activities.

**QUARTERLY:**

1. Spray buff/polish all vinyl tile, terrazzo, decorative stained concrete, and hard surface floors as appropriate with a high speed buffing machine (1500 rpm's).
2. Deep clean all carpets with an extractor machine.
3. Pressure wash or steam clean all tile and enamel floors in restrooms, locker rooms, showers and wet areas.
4. Clean other/special flooring types, hardwood or composite rubber sports flooring, "mondo-type" resilient flooring, etc. as per manufacturer's recommendations.

**ANNUALLY:**

1. Machine scrub, rinse with clear water and re-coat with floor finish all vinyl tile, terrazzo, and decorative concrete flooring. The floor finish must have three (3) coats of finish containing 25% solids or four (4) coats containing 21% solids and two (2) coats of sealer. When dry, the re-coated flooring must be buffed with a high speed buffing machine of at least 1500 RPM's.
2. Clean other/special flooring types, hardwood or composite rubber sports flooring, "mondo-type" resilient flooring, etc. as per manufacturer's recommendations.

**EXHIBIT A**  
**SCOPE OF SERVICES**  
Pg. 3

**LIST OF FACILITIES**

Bessie Smith Cultural Center	200 MLK Blvd.	Chattanooga	23,255	Sq. Ft.
City Council Building	1000 Lindsay Street	Chattanooga	12,251	Sq. Ft.
City Hall	101 E. 11 <sup>th</sup> Street	Chattanooga	57,770	Sq. Ft.
City Hall Annex	100 E. 11 <sup>th</sup> Street	Chattanooga	34,180	Sq. Ft.
Development Resource Center	1250 Market Street	Chattanooga	82,600	Sq. Ft.
Facilities Management Building	274 E. 10 <sup>th</sup> Street	Chattanooga	7,316	Sq. Ft.
Lindsay Street Building	1001 Lindsay Street	Chattanooga	7,480	Sq. Ft.
WellAdvantage Health and Wellness Center	620 E. 11 <sup>th</sup> Street	Chattanooga	20,526	Sq. Ft.



**EXHIBIT B  
PRICING SCHEDULE**

**CITY HALL CAMPUS**  
101 East 11th Street; Suite G 13  
Chattanooga, TN 37403

The Named Areas will be serviced according to the Cleaning Schedule  
for a minimum monthly charge of:  
(Tax Not Included)

**MAINTENANCE**

Bessie Smith Cultural Center

Twenty Nine Thousand Eight Hundred Sixty Nine and No/100 Dollars

(\$29,919.00)

PER YEAR

Five (5) Times Weekly

**City Council Building**

Fifteen Thousand Seven Hundred Thirty Seven and No/100 Dollars

(\$15,787.00)

PER YEAR

Five (5) Times Weekly

City Hall Building

Seventy Four Thousand Two Hundred Six and No/100 Dollars

(\$74,256.00)

PER YEAR

Five (5) Times Weekly

City Hall Annex

Forty Three Thousand Nine Hundred Twelve and No/100 Dollars

(\$43,962.00)

PER YEAR

Five (5) Times Weekly

Development Resource Center

One Hundred Six Thousand One Hundred One and No/100 Dollars

(\$106,151.00)

PER YEAR

Five (5) Times Weekly

Facilities Management Building

Nine Thousand Four Hundred Eight and No/100 Dollars

(\$9,458.00)

PER YEAR

Five (5) Times Weekly

Lindsay Street Building

Nine Thousand Six Hundred Sixteen and No/100 Dollars

(\$9,666.00)

PER YEAR

Five (5) Times Weekly

WellAdvantage Health and Wellness Center

Twenty Six Thousand Three Hundred Seventy Seven and No/100 Dollars

(\$26,427.00)

PER YEAR

Five (5) Times Weekly

**EXHIBIT B  
PRICING SCHEDULE**

**REQUESTED ADDITIONAL CLEANS**

**FLOORS**

Upon request, the following services can be performed for an additional fee:

- Carpet Shampoo - minimum charge of \$150.00 or \$0.17 per square foot
- Strip, reseal and refinish tile floors- minimum charge of \$150.00 or \$0.245 per square foot.
  - Care will be taken to get into corners, along edges and beneath furniture.
  - Care will be exercised so that baseboards, walls and furniture shall not be splashed, marred, disfigured or damaged during these operations.

**WINDOWS**

Upon request, the following services can be performed for an additional fee:

- Windows can be washed inside and out up to second floor with the use of a step ladder - minimum charge of \$50.00.

**\*Prices are subject to change\***

Date: May 30, 2019

Requisition No.: 184631

**PURCHASING DEPARTMENT  
101 EAST 11<sup>TH</sup> STREET  
CITY HALL  
SUITE G13  
CHATTANOOGA, TENNESSEE  
37402**

**Request for Bid (RFB) for the City of Chattanooga, Tennessee**

*Proposals will be received at 101 East 11<sup>th</sup> Street, Suite G13,  
Chattanooga, TN 37402 until 2:00 P.M., EST. on June 13, 2019*

**Requisition / Bid No.: R184631 / 305548**

**Ordering Dept.: Facilities Management**

**Buyer & E-mail: Mark McKeel mmckeel@chattanooga.gov**

\*\*\*\*\*

**Items Being Purchased: Floor Cleaning & Related Services for  
City Hall Campus**

\*\*\*\*\*

**\*\*\*REQUEST FOR BIDS MUST BE RECEIVED\*\*\***

**2:00 P.M., EST on June 13, 2019**

\*\*\*\*\*

**\*\*\*PRE-BID CONFERENCE WILL BE CONDUCTED\*\*\***

**10:30 A.M., EST on June 6, 2019**

\*\*\*\*\*

The City of Chattanooga reserves the right to reject any and/or all proposals, waive any informalities in the proposals received, and to accept any proposal which in its opinion may be for the best interest of the City.

The City of Chattanooga will be non-discriminatory in the purchase of all goods and services on the basis of race, color or national origin.

The City's Standard Terms and Conditions may be found on website:  
<http://www.chattanooga.gov/purchasing/standard-terms-and-conditions>

**Note: ALL BIDS MUST BE SIGNED**

All proposals received are subject to the terms and conditions contained herein and as listed in the above referenced website. The undersigned Offeror acknowledges having received, reviewed, and agrees to be bound to these terms and conditions, unless specific written exceptions are otherwise stated.

**PLEASE PROVIDE THE FOLLOWING INFORMATION:**

Company Name: Juni-King of Chattanooga

Mailing Address: 7610 Hamilton Park Dr; Suites 3+4

City & Zip Code: Chattanooga, TN 37421

Phone/Toll Free No.: 423-648-3101

Fax No.: 423-648-3113

E-Mail Address: jsherwood@jkccs.com

Contact Person: Josh Sherwood

Company Title: Regional Director

Signature: [Handwritten Signature]

# BID SOLICITATION



City of Chattanooga  
101 East 11th Street, Suite G13  
Chattanooga, TN 37402

<b>BID OPENING DATE AND TIME:</b> 13-JUN-19 at 2:00 PM
<b>BID NUMBER:</b> 305548
<b>BUYER:</b> <b>PHONE #:</b> (423) 643-7230 <b>DELIVERY REQUIRED:</b>

**SEALED BIDS**  
Mail or submit two (2) signed copies of bid form to this office in the enclosed envelope. Retain one copy for your file.

<b>V</b>	
<b>E</b>	RFQ
<b>N</b>	
<b>D</b>	
<b>O</b>	
<b>R</b>	

<b>M</b>	City of Chattanooga
<b>A</b>	101 East 11th Street, Suite G13
<b>I</b>	Chattanooga, TN 37402
<b>L</b>	
<b>T</b>	
<b>O</b>	

Item	Class-Item	Quantity	Unit	Unit Price	Total
Requisition / Bid No : 184631 / 305548 Ordering Dept : Facilities Management, Public Works Buyer: Mark McKeel Phone No.: 423-643-7236  Items Being Purchased: Floor Cleaning & Related Services for City Hall Campus  <b>ATTACHMENTS:</b> 1. Specifications (12 pages) 2. Affirmative Action Plan (2 pages) 3. Iran Divestment Act Disclosure (1 page) 4. No Contact / No advocacy Notice (1 page) City of Chattanooga (COC) Terms and Conditions posted on Website <a href="http://www.chattanooga.gov/purchasing/standard-terms-and-conditions">http://www.chattanooga.gov/purchasing/standard-terms-and-conditions</a> If you can't download call buyer for a copy.  NOTE: A Pre-Bid Conference will be held June 6, 2019 at 10:30 AM, at City Hall, Purchasing Conference Room 101 East 11th Street, Suite G13, Chattanooga, TN 37402. Attendance at the Pre-Bid is Preferred  This Shall Be A Twelve (12) Month Blanket Contract To Supply Floor Cleaning & Related Services for City Hall Campus  The Contract Term May Be Renewed For An Additional Two (2) Twelve (12) Month Terms Under The Same Terms And Conditions By Mutual Agreement The City Of Chattanooga And The Contractor May Bilaterally Extend The Contract By Providing Written Confirmation Of Agreement By Both Parties At Least 30 Days Prior To The Contract's Current Expiration Date Into Any Successive Term As Provided Herein.  QUANTITIES ARE ESTIMATES ONLY THE CITY OF CHATTANOOGA SHALL GUARANTEE NO MINIMUM OR MAXIMUM AMOUNT PURCHASED DURING THE LIFETIME OF THE CONTRACT  *** BID MUST BE RECEIVED NO LATER THAN *** *** 2:00 PM EST ON JUNE 13, 2019 ***  PLEASE SUBMIT BIDS IN DUPLICATE INDICATING BID NUMBER (305548) ON OUTSIDE PACKAGING  PLEASE DO NOT EMAIL BIDS  **** Vendor Shall Hold Prices Firm for First (1st) Year of Contract ****  Price Escalation Clause: If as a result of a general change in prices or discounts, the Contractor has changed prices to all of its customers, the price under this contract may be adjusted accordingly Contractor may be requested to show proof of alleged price changes prior to approval of any price adjustments.  NOTE: ALL BIDS MUST BE SIGNED All bids received are subject to the terms and conditions contained herein and as listed in the above referenced website. The undersigned Bidder acknowledges					

# BID SOLICITATION



**City of Chattanooga**  
 101 East 11th Street, Suite G13  
 Chattanooga, TN 37402

**BID OPENING DATE AND TIME:**  
 13-JUN-19 at 2:00 PM

**BID NUMBER:** 305548

**BUYER:**  
**PHONE #:** (423) 643-7230  
**DELIVERY REQUIRED:**

SEALED BIDS

Mail or submit two (2) signed copies of bid form to this office in the enclosed envelope. Retain one copy for your file.

V  
E  
N  
D  
O  
R

RFQ

M City of Chattanooga  
 A 101 East 11th Street, Suite G13  
 J Chattanooga, TN 37402  
 L  
 T  
 O

Item	Class-Item	Quantity	Unit	Unit Price	Total
having received, reviewed, and agrees to be bound to these terms and conditions, unless specific written exceptions are otherwise stated.  Any manufacturers names, trade names, brand names, or catalog numbers used in the specifications are for the purpose of describing and establishing general quality levels. Such references are not intended to be restrictive. Bids will be considered for any brand which meets or exceeds the quality of the specifications listed for any item.  The City of Chattanooga reserves the right to reject any and/or all bids, waive any informalities in the bids received, and to accept any bid which in its opinion may be for the best interest of the city.  The City of Chattanooga will be non-discriminatory in the purchase of all goods and services on the basis of race, color, or national origin.  **** NOTE **** PLEASE PROVIDE US WITH THE FOLLOWING INFORMATION:  Company Name <u>Jani-King of Chattanooga</u> Address <u>7610 Hamilton Park Dr; Suites 3+4</u> <u>Chattanooga, TN 37421</u> Phone/Toll-Free No <u>423-648-3101</u> Fax No <u>423-648-3113</u> eMail Address <u>j.sherwood@jkccs.com</u> Contact Person's Name <u>Josh Sherwood</u> Estimated Delivery <u>6-13-19</u>  Minority-Owned Business _____ Small Business _____ Veteran _____ Minority Woman Owned Business _____ Disabled Veteran _____ Woman-Owned Business _____  **** ALL ITEMS MUST BE QUOTED F O B DESTINATION ****					

NOTE: ALL BIDS RECEIVED ARE SUBJECT TO THE TERMS AND CONDITIONS

The City is Exempt from all Federal and State Tax. Bids will be received at the above mentioned address.

TERMS OF PAYMENT: Net 30

TELEPHONE NUMBER: 865-671-5464

ALL BIDS MUST BE SIGNED – The undersigned offers the above quoted prices under the conditions contained herein.

COMPANY Jani-King of Chattanooga

SIGNATURE [Signature]

NAME AND TITLE: Josh Sherwood - Regional Director

# BID SOLICITATION



City of Chattanooga  
 101 East 11th Street, Suite G13  
 Chattanooga, TN 37402

**BID OPENING DATE AND TIME:**  
 13-JUN-19 at 2:00 PM

**BID NUMBER: 305548**

**BUYER:**  
 PHONE #: (423) 643-7230  
 DELIVERY REQUIRED:

SEALED BIDS

Mail or submit two (2) signed copies of bid form to this office in the enclosed envelope. Retain one copy for your file.

V  
E  
N  
D  
O  
R

RFQ

M  
A  
I  
L  
I  
N  
G

City of Chattanooga  
 101 East 11th Street, Suite G13  
 Chattanooga, TN 37402

Item	Class-Item	Quantity	Unit	Unit Price	Total
1	RFB Contract To Provide Floor Cleaning and Related Services For City Of Chattanooga Facilities	200000	Year	_____	_____

NOTE: ALL BIDS RECEIVED ARE SUBJECT TO THE TERMS AND CONDITIONS

The City is Exempt from all Federal and State Tax.  
 Bids will be received at the above mentioned address.

TERMS OF PAYMENT Net 30

TELEPHONE NUMBER 865-671-5464

ALL BIDS MUST BE SIGNED – The undersigned offers the above quoted prices under the conditions contained herein.

COMPANY Jeni-King of Chattanooga

SIGNATURE [Signature]

NAME AND TITLE Regional Director  
 Josh Shewood

# **INVITATION TO BID**

**CONTRACT SERVICES  
FOR  
CONTRACT TO PROVIDE**

**FLOOR CLEANING AND RELATED SERVICES**

**FOR**

**CITY OF CHATTANOOGA FACILITIES**

**June, 2019**



## OVERVIEW

The City is seeking a contractor to provide FLOOR CLEANING AND RELATED SERVICES with a performance-based quality of standards for the City of Chattanooga TN on an annual contract basis. The awarded Contractor will be responsible for the professional quality, technical accuracy, and the coordination of all services provided.

Any Blanket Contract for services described herein shall be for a period of one (1) year, with two (2) additional optional one (1) year renewal periods, upon agreement of both parties. Services will be provided only at the above mentioned location.

The City intends to contract with one Contractor.

The awarded Contractor shall comply with all the applicable provisions of the Local, State, and Federal laws including any required Professional Certifications.

## GENERAL INSTRUCTIONS TO PROPOSERS

**Sealed Bids must be submitted in hard copy format to the Purchasing Division, City of Chattanooga, by no later than 2:00 p.m., EDT, on June 13, 2019 to the attention of:**

City of Chattanooga Purchasing Division  
Attn: Mark McKeel  
101 East 11<sup>th</sup> Street  
Suite G13  
Chattanooga, TN 37402  
Phone: (423) 643-7236  
Fax: (423) 643-7244

Late or misdirected bids shall be rejected and returned unopened without exception. Postmarks are not accepted.

### Pre-Bid Meeting

An Optional Pre-Bid Meeting will be held on June 6, 2019 at 10:30 AM EST at City of Chattanooga Purchasing Division, 101 East 11th Street, Chattanooga, TN 37402. The scope of this meeting will be to review the content of the Bid document. Questions must be submitted in writing, to allow for formal response.

It is the responsibility of each proposer to visit the provided list of facilities (Attachment C) to determine the nature of the floor cleaning and related services which may be required as a part of this contract, the associated work areas and conditions, the safety requirements, and any other circumstances associated with the provision of these floor cleaning and related services.

### Quantity and Format

Proposer shall submit seven (7) complete copies of their bid; one (1) original, five (5) copies and one (1) electronic copy in PDF format on a flash drive. All bids shall be submitted in a sealed non-transparent

envelope or box marked "ITB 305548" - CONTRACT TO PROVIDE FLOOR CLEANING AND RELATED SERVICES FOR CITY OF CHATTANOOGA FACILITIES.

Detailed Technical Bids

Complete technical submittals shall be submitted with the Bid. These technical submittals shall describe in detail how the Proposer complies with each specification requirement of the ITB. Any deviations from the specifications shall be noted.

Implied Requirements

All products and services not specifically mentioned in this ITB, but which are necessary to provide the functional capabilities described by the Proposer, shall be included in the Bid.

Proposer Supplied Materials

Any material submitted by a Proposer shall become the property of the City unless otherwise requested at the time of submission. **Any firm submitting a bid should assume the information included in the bid is subject to Open Records / Freedom of Information Act.**

Incurring Costs

The City shall not be liable for any cost incurred by the proposer prior to the issuance of a contract purchase agreement and will not pay for the information solicited or obtained. Proposer shall not include or integrate any such expense as part of its bid.

Economy of Preparation

Bids shall be prepared simply and economically. Bids shall provide a straightforward and concise bid description. Emphasis shall be placed on clarity and content.

Bid Withdrawal Procedure

A Bid may be withdrawn at any time until the date and time set above for opening of bids. Any bid not so withdrawn shall, upon opening, constitute an irrevocable offer to provide the specifications set forth in the bid, until the successful bid(s) is/are accepted and a contract has been executed between the City and the successful Proposer(s).

General Reservation of City Rights

The City of Chattanooga may contact any firm for the purpose of obtaining additional information or clarification.

General Terms

Any contract resulting from this Bid will be subject to the City of Chattanooga's Standard Terms and Conditions.

[http://www.chattanooga.gov/images/City\\_of\\_Chattanooga\\_-\\_Standard\\_Terms\\_and\\_Conditions\\_Revised\\_7.18.2018.pdf](http://www.chattanooga.gov/images/City_of_Chattanooga_-_Standard_Terms_and_Conditions_Revised_7.18.2018.pdf)

Any exceptions to said Terms and Conditions must be submitted with Bid response.

Proposers shall state any exceptions to or deviations from the terms of this Bid and the Standard Terms and Conditions. Where proposer wishes to propose alternative approaches to meeting the City's

technical or contractual requirements, these should be thoroughly explained. The Contractor shall be bound to accept all stated terms not except in its bid.

City reserves the right to accept or reject any or all exceptions / deviations at its sole discretion. City reserves the right to reject excepted or conditional bids at its sole discretion.

Any resulting contract shall NOT be open to other Tennessee governmental agencies (including school districts) as a "piggyback contract".

**ADDITIONAL BID INFORMATION**

All questions, and requests for information or clarification (including those developed during the Pre-Bid meeting) must be submitted in writing, and will be accepted until 4:00 PM on June 10, 2019, and shall be sent to:

City of Chattanooga Purchasing Division  
Attn: Mark McKeel, Buyer  
101 East 11<sup>th</sup> Street  
Suite G13  
Chattanooga, TN 37402  
Phone: (423) 643-7236  
Fax: (423) 643-7244  
mmckeel@chattanooga.gov

The City specifically requests that any communication concerning this ITB be made exclusively with the Purchasing Division Buyer until selection has been completed. Failure to honor this request will be negatively viewed in the selection process.

## **BID SCOPE OF WORK**

This scope of services included in these Specifications is FLOOR CLEANING AND RELATED SERVICES with a performance-based quality of standards for the **City of Chattanooga TN**. As a performance-based contract, the required services are stated in terms of desired results and quality standards with specifications in accordance with all federal, state, county and city laws, codes and ordinances. The Contractor shall also follow standard industry practices as set forth by the Occupational Safety and Health Act (OSHA).

The Contractor's bid is to include personnel, labor, equipment, material, tools, supplies, supervision, management, and services, except as may be expressly set forth as furnished by the City of Chattanooga. Training and personal protective equipment (PPE) are the sole responsibility of the Contractor.

All contractors submitting bids shall have the following bonds and insurance in the types and minimum amounts listed below and, if awarded a contract, shall maintain such bonds and insurance throughout the contract period. (Bond and Insurance Documents must accompany all bids).

- A. Employee Dishonesty Bond - limits to twenty five thousand dollars (\$25,000)
- B. Property Damage and Liability Insurance - limits to one million dollars (\$1,000,000)
- C. Workmen's Compensation - a one hundred percent (100%) performance bond with five percent (5%) bid bond
- D. Certificate of Insurance
- E. Minimum of two (2) years (recommended) floor cleaning experience with commercial type institutions and produce a list of recent relevant references.

Failure to produce the above listed documents with the submitted bid will result in the disqualification of the bid.

Successful Contractor shall be liable for any and all damages caused by their employees, agents or subcontractors, including but not limited to replacing door locks, rekeying lock cylinders, key cutting charges and replacement access control cards resulting from the loss or misplacement of assigned keys or access cards to the facility. Contractor damage to any City of Chattanooga property is to be repaired or replaced strictly at the Facilities Manager's sole discretion.

## **SECURITY REQUIREMENTS & FEDERAL/STATE FEE**

The successful Contractor must complete the following requirements.

### **CJIS SECURITY POLICY 5.12.1.1**

Minimum Screening Requirements for Individuals requiring access to CJIS:

1. To verify identification, a state of residency and national fingerprint-based record checks shall be conducted within 30 days of assignment for all personnel who have direct access to CJIS (Criminal Justice Information).
2. Support personnel, contractors, and their agents or employees with access to physically secure locations or controlled areas (during CJIS processing) shall be subject to a state and national fingerprint-based record check unless these individuals are escorted by authorized personnel at all times.

CJIS SECURITY POLICY 5.12.1.2

Personnel Screening for Contractors and Vendors

1. Prior to granting access to CJI, the CGA (Contracting Government Agency) on whose behalf the Contractor is retained shall verify identification via a state of residency and national fingerprint-based record checks.
2. A Contractor employee found to have a criminal record consisting of felony conviction(s) shall be disqualified.

*There will be a TBI Cogent fee of approximately \$42.00 per person for owners, partners, managing agents, supervisors, employees and their subcontractors entering the Premises is to be electronically sent by Identogo finger print site located at 6231 Perimeter Drive Ste. 177 Chattanooga, TN 37421.*

All owners, partners, or managing agents of the Contractor must be able to pass a Level 3 background check and Contractor, including their owners, employees, agents or subcontractors who enter the facility may be asked to sign N.C.I.C. and local criminal history and record authorization forms and must be approved by a Facilities Management supervisor before entering the premises.

After the clearance of the prospective employee, an I.D. card will be issued and must be worn so that it is clearly visible at all times when the Contractor's employees are on the premises. Upon termination of the Contract for any reason, the Contractor shall return all ID cards and keys to the Facilities Manager. Lost ID cards or ID cards not returned at the end of the Contract will be subject to no less than a ten dollar (\$10) replacement fee which will be withheld from the Contractor's final invoice. IF ANY KEYS ARE LOST/MISPLACED AND DOOR LOCKS AND/OR KEYS HAVE TO BE REPLACED AT CONTRACTORS EXPENSE, THE WORK SHALL BE PERFORMED BY A LOCKSMITH TO BE DESIGNATED BY THE FACILITY MANAGER. IN THE EVENT OF AN EMERGENCY SITUATION AND A LOCKSMITH HAS TO BE CALLED AND ANY LOCKS/KEYS HAVE TO BE REPLACED, THE SAME TYPE/BRAND OF LOCK/KEY SHALL BE PURCHASED.

Contractor shall be liable for any and all keys issued to their employees for office access within the premises. These keys shall be kept in a designated area at all times except while employees are cleaning. No office shall be left unlocked while unattended. The Contractor's employees shall not unnecessarily disturb nor remove personal items from any area. All offices and designated areas must be locked after cleaning. All services performed under this contract shall be performed while under the direct supervision of the Contractor's floor cleaning supervisor.

Contract shall include any areas within the premises which may be enclosed or constructed during the term of this contract, provided that they do not increase the total square footage of floor space of the premises or substantially alter the quantity and type of surface to be maintained.

Contractor shall ensure that they have an able bodied employee on the premises, at all times, who is capable of regular and routine lifting of heavy objects up to 50 pounds, emptying trash, moving furniture, etc. and any other strenuous activities reasonably encountered during the performance of the work under this contract.

The Contractor shall designate representative who is responsible for written and oral communication with the Facility Manager and the City of Chattanooga and this representative shall be capable of clear communications and making binding decisions on behalf of the Contractor and shall be the primary source of communication between the Facility Manager and Contractor.

Contractor shall provide all chemicals, cleaning equipment, cleaning products, mops, brooms, buckets and other items necessary to accomplish cleaning in a professional and acceptable manner. The City of Chattanooga reserves the right to request a change in chemicals should any staff member, client, or affiliate become sensitive or allergic to any product used. The Contractor certifies that all products contained in this bid meets all ANSI, NFPA and all other Federal, State and local requirements. The Contractor will provide to the Facility Manager within ten (10) business days following the contract start date, a binder including the Safety Data Sheets (SDS) for all products and materials that will be used, consumed or stored on the Premises. An exact duplicate copy of this SDS binder shall be maintained on the Premises at all times. The Contractor is responsible for submitting new SDS to the Facility Manager upon use of a new products and shall update the SDS binder at the time any new material is brought onto the Premises. Should a product cease to be utilized, the Contractor must communicate such to the Facility Manager and update the SDS accordingly so that the SDS binder is up to date at all times. The Contractor shall maintain adequate inventory of materials and supplies in the areas designated by the Facility Manager. Maintaining small stock of items in restrooms, utility closets and other areas throughout the Premises not designated as storage will not be permitted. The Contractor shall dispose of all waste generated in designated trash areas or remove from the premises for off-site disposal. Contractor shall keep their stock/storage rooms clean, orderly, and trash free. Dirty mop water shall be emptied nightly. Anytime any floor cleaning work is being performed in any facility, Contractor shall be responsible for posting standard warning signs such as – “WET FLOOR” and closing off the area until the floor is safe to walk on.

Occasionally, in the course of cleaning work at a facility the Contractor and/or their staff may come into contact with bio-hazardous waste. It will be the responsibility of the Contractor to provide training and ensure that their staff receives proper handling instructions for such occurrences.

#### **TERM OF CONTRACT**

Contract for floor cleaning and Related Services shall begin on July 1, 2019 and continue through June 30, 2020.

The Contractor shall submit to the City of Chattanooga invoices for services provided in even monthly installments such that the sum of all monthly invoices total the exact contract amount. Invoices are due after service has been rendered with the first invoice due on August 1, 2019 and on the first (1<sup>st</sup>) day of each month thereafter throughout the remainder of the contract and any contract extensions. The monthly invoice shall be sent to: City of Chattanooga (Accounts Payable Division) 101 East 11<sup>th</sup> Street, Suite 101 Chattanooga, TN 37402 during the last week of each and every month for the preceding month's service.

Attachment A  
SPECIFICATIONS AND SCOPE OF WORK

Scope of work for services shall include the City of Chattanooga facilities specified in Attachment C. However, the City reserves the right to remove facilities from the scope of work during the contract term with thirty (30) days' notice to the contractor. Following any such removal of a facility from the scope of work, the remaining portion of the contract amount shall be adjusted on a pro-rata/sf basis through the end of the contract term to reflect the revised scope of work.

**Additions to Scope of Work.** At any time during the term of the contract, and with two (2) weeks' notice to the contractor, the City may desire to add facilities to the scope of work. The contractor shall be given the opportunity to accept the additional scope of work with reimbursement to be paid at the current contract rates. Should the contractor agree to the addition to the scope of work, the contract amount shall be adjusted on a pro-rata/sf basis through the end of the contract term to reflect the revised scope of work. However, should the contractor choose not to accept the additional scope of work within two (2) weeks of notification from the City, the City shall be under no obligation to the contractor for the proposed additional scope of work and the City reserves the right to pursue any other options, including soliciting bids and contracting with other parties for that scope of work.

The floor cleaning services shall be performed generally between the hours of 5:00 p.m. and 10:00 p.m., Monday through Friday, five (5) days per week, excluding published City of Chattanooga holidays. Facilities Manager reserves the right to change the above days or hours for the benefit of the City. A two (2) weeks' notice will be given for any changes to the regular schedule.

ADDITIONAL REQUIREMENTS

- 1) Any needed service that is outside the scope of this contract must be approved by the Facilities Manager. If the service is not approved, corrections must be made and completed to meet specifications and approval within forty-eight (48) hours. If approval is not granted within forty-eight (48) hours there will be a \$100.00 per day penalty until satisfactorily completed.
- 2) A representative of the Contractor must be immediately available to handle any verbal complaint. Verbal complaints must be corrected within 24 hours of the notification.
- 3) Awards shall be made to the responsible and responsive Contractor submitting the best bid considering the following:
  - a) Conformity to Specifications
  - b) Price
  - c) Ability to Perform
- 4) Contractor shall be responsible for repairing/replacing tile grout, tile, carpet, hardwood floors, wall surfaces, trim, furniture, permanent or temporary fixtures of any kind should Contractor cause permanent damage, staining, corrosion, discoloration, tarnishing or bad appearance to any of the above whether or not it was done purposely or accidentally. Should the above occur, the repairs/replacements shall be to the satisfaction of the Facilities Manager.

- 5) The Contractors shall respond promptly and within ten (10) business days to any written complaints by or through the Facility Manager regarding their employees or services provided and shall specify what action will be taken to prevent further complaints.

The Contractor shall provide the tasks and services under the contract for floor cleaning services according to the scope of work and scheduled frequencies below:

**INITIAL CLEANING:** Upon inspection of the City of Chattanooga facilities specified in Attachment C, the contractor shall determine that additional up-front work is required to bring the facilities up to a standard and maintainable condition. This initial cleaning shall be a lump-sum amount for all materials, equipment and labor required and shall be applicable only at the beginning of the initial term of the contract.

**DAILY: (Five (5) days per week – Monday through Friday)**

- 1) **BARE FLOOR CARE:**
  - a) Bare floors, base moldings, and grout shall be clean and free of debris including but not limited to dirt, water streaks, mop marks, string, gum, tar, and other foreign matter. The floors shall maintain their natural luster and not have a dull appearance.
  - b) Bare floors shall be swept and/or dust mopped with dust control treated mops.
  - c) Wet mopping of bare floors shall be cleaned using disinfectant cleaner(s). Surfaces, baseboards, and corners shall be clean and dry.
  - d) Walls, baseboards, and other surfaces shall be free of splashing and markings from the equipment. There shall be no visible buildup of finish in corners or crevices.
  - e) Mops and cleaning rags shall be cleaned and sanitized before and after each day of use. Mops and cleaning rags used in restrooms shall not be used to clean any other areas.
  - f) Spot mop all tile floors and remove all spots caused by spillages.
  - g) Main lobby floors shall be spray buffed as needed followed by dust mopping with dust control treated mop.
- 2) **CARPETS AND RUGS:**
  - a) Vacuuming: Carpet surfaces are to be free of dirt, dust, and other debris. Vacuuming shall be done at a frequency that will protect the integrity of the carpet and prolong wear. HEPA filtration vacuums are required.
  - b) Carpet edges and baseboards shall be swept or vacuumed with a wand attachment to remove particles from edges.
  - c) Spot Cleaning: Carpet surfaces shall be free of removable spots, soiled traffic patterns, dirt, dust, debris, gum, and crusted materials.
- 3) **TILE FLOORS, RESTROOMS, SHOWERS:**
  - a) All floors shall be thoroughly swept and wet mopped with anti-bacterial detergent and rinsed thoroughly.
  - b) Fittings and supply pipes will be kept clean any cleaning materials, splashes, or spillage caused by the contractor.
- 4) **MISCELLANEOUS:**
  - a) Decorative private offices and reception areas shall be given special attention in keeping with any special floor finishes.



- b) Keep all baseboards, doors, door kick-plates and furniture bases clean.
- c) Sweep all outside entrances.
- d) Clean and organize any designated storage areas.
- e) Shut off all interior lights.
- f) Close and lock all designated interior doors.
- g) Ensure that all exterior doors are properly closed and locked,
- h) Notify police of any incidents or suspicious activities.

**QUARTERLY:**

1. Spray buff/polish all vinyl tile, terrazzo, decorative stained concrete, and hard surface floors as appropriate with a high speed buffing machine (1500 rpm's).
2. Deep clean all carpets with an extractor machine.
3. Pressure wash or steam clean all tile and enamel floors in restrooms, locker rooms, showers and wet areas.
4. Clean other/special flooring types, hardwood or composite rubber sports flooring, "mondo-type" resilient flooring, etc. as per manufacturer's recommendations.

**ANNUALLY:**

1. Machine scrub, rinse with clear water and re-coat with floor finish all vinyl tile, terrazzo, and decorative concrete flooring. The floor finish must have three (3) coats of finish containing 25% solids or four (4) coats containing 21% solids and two (2) coats of sealer. When dry, the re-coated flooring must be buffed with a high speed buffing machine of at least 1500 RPM's.
2. Clean other/special flooring types, hardwood or composite rubber sports flooring, "mondo-type" resilient flooring, etc. as per manufacturer's recommendations.

Attachment B  
BID SUBMITTAL FORM

ITEMS

- |  |                   |               |
|--|-------------------|---------------|
| A) Initial Cleaning Tasks  | \$ <u>Ø</u>       | One Time Cost |
| B) Bessie Smith Cultural Center  | \$ <u>29,919</u>  | Annually      |
| C) City Council Building   | \$ <u>15,787</u>  | Annually      |
| D) City Hall   | \$ <u>74,256</u>  | Annually      |
| E) City Hall Annex   | \$ <u>43,962</u>  | Annually      |
| F) Development Resource Center   | \$ <u>106,151</u> | Annually      |
| G) Facilities Management Building  | \$ <u>9,458</u>   | Annually      |
| H) Lindsay Street Building   | \$ <u>9,666</u>   | Annually      |
| I) WellAdvantage Health and Wellness Center  | \$ <u>26,427</u>  | Annually      |
| J) Urgent/Special Cleaning Tasks on a Time & Materials Basis: <b>Attach Rate Sheet for Labor and Equipment to the Bid Document</b> |                   |               |

(City reserves the right to withdraw Item J from the bid, at its sole discretion)

FIRST-YEAR TOTAL ANNUAL COST OF SERVICES (Sum of Items A-I) \$ 315,626.00

SECOND-YEAR TOTAL ANNUAL COST OF SERVICES (Sum of Items B-I) \$ 315,626.00

Bidder:

  
Signature

6-13-19  
Date

Jani King of Chattanooga  
Firm Name

7610 Hamilton Park Dr; Suites 3+4  
Address

Chattanooga, TN 37421

423-648-3101  
Phone Number

Attachment C  
LIST OF FACILITIES

Bessie Smith Cultural Center	200 MLK Blvd	Chattanooga	23,255	Sq. Ft.
City Council Building	1000 Lindsay Street	Chattanooga	12,251	Sq. Ft.
City Hall	101 E 11th Street	Chattanooga	57,770	Sq. Ft.
City Hall Annex	100 E 11th Street	Chattanooga	34,180	Sq. Ft.
Development Resource Center	1250 Market Street	Chattanooga	82,600	Sq. Ft.
Facilities Management Building	274 E 10th Street	Chattanooga	7,316	Sq. Ft.
Lindsay Street Building	1001 Lindsay Street	Chattanooga	7,480	Sq. Ft.
WellAdvantage Health and Wellness Center	620 E 11th Street	Chattanooga	20,526	Sq. Ft.

## Affirmative Action Plan

The City of Chattanooga is an equal opportunity employer and during the performance of this Contract, the Contractor agrees to abide by the equal opportunity goals of the City of Chattanooga as follows:

1. The Contractor will not discriminate against any employee or applicant for employment because of race, color, religion, sex, national origin, or handicap. The Contractor will take affirmative action to ensure that applicants are employed, and the employees are treated during employment without regard to their race, color, religion, sex, national origin, or handicap. Such action shall include, but not be limited to, the following: employment, upgrading, demotion, or transfer, recruitment or recruitment advertising, layoff or termination, rates of pay, or other forms of compensation, and selection for training, including apprenticeship. The Contractor agrees to post in conspicuous places, available to employees and applicants for employment, notices setting forth the provisions of this nondiscrimination clause.
2. The Contractor will, in all solicitations or advertisements for employees placed by or on behalf of the Contractor, state that all qualified applicants will receive consideration for employment without regard to race, color, religion, sex, national origin, or handicap.
3. The Contractor will send to each labor union or representative of workers with which he/she has a collective bargaining agreement or other contract or understanding, a notice advising the said labor union or workers' representatives of the Contractor's commitments under this section, and shall post copies of the notice in conspicuous places available to employees and applicants for employment.
4. In all construction contracts or subcontracts in excess of \$10,000 to be performed for the City of Chattanooga, any contractor and/or subcontractor is further required to file in duplicate within ten (10) days of being notified that it is the lowest responsible bidder, an affirmative action plan with the EEO Director of the City of Chattanooga. This plan shall state the Contractor's goals for minority and women utilization as a percentage of the work force on this project.
5. This Plan or any attachments thereto shall further provide a list of all employees annotated by job function, race, and sex who are expected to be utilized on this project. This plan or attachment thereto shall further describe the methods by which the Contractor or Subcontractor will utilize to make good faith efforts at providing employment opportunities for minorities and women.

During the term of this contract, the Contractor upon request of the City, will make available for inspection by the City of Chattanooga copies of payroll records, personnel documents and similar records or documents that may be used to verify the Contractor's compliance with these Equal Opportunity provisions.

6. The Contractor will include the portion of the sentence immediately preceding paragraph 1 and the provisions of paragraphs 1 through 6 in every subcontract so that such provisions will be requested of each subcontractor. The Contractor agrees to notify the City of Chattanooga of any subcontractor who refuses or fails to comply with these equal opportunity provisions. Any failure or refusal to comply with these provisions the Contractor and/or Subcontractor shall be a breach of this contract.

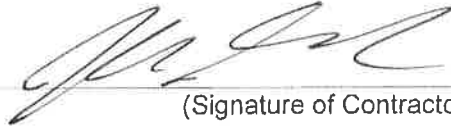

---

(Signature of Contractor)

Josh Sherwood - Regional Director - Jani-King of Chattanooga

---

(Title and Name of Construction Company)

6-13-14

---

(Date)

Chapter No. 817 (HB0261/SB0377). "Iran Divestment Act" enacted.  
Vendor Disclosure and Acknowledgement

By submission of this bid, each bidder and each person signing on behalf of any bidder certifies, and in the case of a joint bid each party thereto certifies as to its own organization, under penalty of perjury, that to the best of its knowledge and belief that each bidder is not on the list created pursuant to § 12-12-106.

(SIGNED)



(PRINTED NAME)

Josh Sherwood

(BUSINESS NAME)

Juni-King of Chattanooga

(DATE)

6-13-19

For further information, please see website:

[https://www.tn.gov/assets/entities/generalservices/cpo/attachments/List\\_of\\_persons\\_pursuant\\_to\\_Tenn.\\_Code\\_Ann.\\_12-12-106,\\_Iran\\_Divestment\\_Act-July.pdf](https://www.tn.gov/assets/entities/generalservices/cpo/attachments/List_of_persons_pursuant_to_Tenn._Code_Ann._12-12-106,_Iran_Divestment_Act-July.pdf)

No Contact/No Advocacy  
Notice Receipt  
City of Chattanooga  
Purchasing Division

For Submission with Sealed Bid Solicitation Responses:

Josh Sherwood

(Vendor Agent name), states that:

(1) He/She is the owner, partner, officer, representative, or agent of Juni - King of

Chattanooga

(Business name), the Submitter of the

attached sealed solicitation response to Solicitation # 305548, and said

Business has taken notice, and will abide by the following No Contact and No Advocacy clauses:

**NO CONTACT POLICY:** After the posting of this solicitation, a potential submitter is prohibited from directly or indirectly contacting any City of Chattanooga representative concerning the subject matter of this solicitation, unless such contact is made with the Purchasing Division.

**NO ADVOCATING POLICY:** To ensure the integrity of the review and evaluation process, companies and/or individuals submitting sealed solicitation responses, as well as those persons and/or companies formally/informally representing such submitters, may not directly or indirectly lobby or advocate to any City of Chattanooga representative.

**Any business entity and/or individual that does not comply with the No Contact and No Advocating policies may be subject to the rejection or disqualification of its solicitation response from consideration.**

Submitter Signature:



Title: Regional Director

Date: 6-13-19

Printed Name:

Josh Sherwood

**ADDENDUM NO: 1**

**REQ NO: 184631**

**FINAL SUBMITTAL: June 13, 2019 at 2:00 PM EST**

**FINAL QUESTIONS: June 10, 2019 at 2:00 PM EST**

**Department: Facilities Management Division, Public Works**

**Changes to Bid# 305548:**

After the pre-bid yesterday, those who came to the pre-bid asked if a walk-through of the buildings could be done. There will be a walk-through starting at the Development Resource Building, 1250 Market Street, at 10:30 AM.

This will be sent out on an addendum as soon as the walk-through is complete.

Total Square Footage of all the Buildings listed is approximately 223,000 square foot. There is 163,000 square foot of Carpet areas and 60,000 square foot of hard surface flooring.

**Req No: 184631 Floor Cleaning & Related Services for City Hall Campus**

**PLEASE SIGN ONE (1) COPY OF ADDENDUM AND RETURN TO THE PURCHASING DEPARTMENT. RETAIN THE OTHER COPY FOR YOUR FILES.**

Name: Josh Sherwood

Company: Jan-King of Chattanooga

**CITY OF CHATTANOOGA  
PURCHASING DEPARTMENT  
Mark McKeel  
City Hall Suite G13  
CHATTANOOGA, TN 37402  
TELE: (423) 643-7236  
FAX: (423) 643-7244**



**ADDENDUM NO: 2**

**REQ NO: 184631**

**FINAL SUBMITTAL: June 13, 2019 at 2:00 PM EST**

**FINAL QUESTIONS: June 10, 2019 at 2:00 PM EST**

**Department: Facilities Management Division, Public Works**

**Changes to Bid# 305548:**

The following information is requested by Facilities Management with your bids:

1. How many employees will be needed to complete the tasks at each Building?
2. List the equipment that will be used for each type floor for each Building.

**Req No: 184631 Floor Cleaning & Related Services for City Hall Campus**

**PLEASE SIGN ONE (1) COPY OF ADDENDUM AND RETURN TO THE PURCHASING DEPARTMENT. RETAIN THE OTHER COPY FOR YOUR FILES.**

Name: Josh Sherwood

Company: Jani-King of Chattanooga

**CITY OF CHATTANOOGA  
PURCHASING DEPARTMENT  
Mark McKeel  
City Hall Suite G13  
CHATTANOOGA, TN 37402  
TELE: (423) 643-7236  
FAX: (423) 643-7244**



**Jani-King of Chattanooga**

7610 Hamilton Park Dr.  
Suites 3 & 4  
Chattanooga, TN 37421  
(423) 648-3101  
Fax: (423) 648-3113

**United States**

Albuquerque • Alexandria  
Atlanta • Augusta  
Austin • Baltimore  
Baton Rouge • Birmingham  
Boston • Buffalo  
Charleston • Charlotte  
Chattanooga • Chicago  
Cincinnati • Cleveland  
Colton • Columbia  
Columbus • Dallas  
Dayton • Denver  
Detroit • Fort Myers  
Fort Worth • Greensboro  
Greenville/Spartanburg  
Hampton Roads  
Hartford • Hawaii  
Houston • Huntsville  
Indianapolis • Jacksonville  
Kansas City • Knoxville  
Lafayette/Lake Charles  
Las Vegas • Lexington  
Little Rock • Los Angeles  
Louisville • Madison  
Macon/Memphis • Miami  
Milwaukee • Minneapolis  
Mississippi Coast • Mobile  
Montgomery • Monroe  
Myrtle Beach • Nashville  
New Jersey • New Orleans  
New York • Oakland  
Oklahoma City • Omaha  
Orlando • Pensacola  
Philadelphia • Phoenix  
Pittsburgh • Portland  
Raleigh/Durham  
Reno • Rhode Island  
Richmond Roanoke/Lynchburg  
Sacramento • Salt Lake City  
San Antonio • San Diego  
San Francisco • Savannah  
Seattle • SE Mississippi  
Shreveport Springfield  
St. Louis • Tri-Cities  
Tampa Bay • Tucson • Tulsa  
Washington, D.C. • Wichita

**International**

Australia  
Bahrain  
Belgium  
Brazil  
Canada  
France  
Great Britain  
Greece  
Hong Kong  
Mexico  
New Zealand  
Portugal  
South Africa  
Spain  
Taiwan  
Toronto/Windsor

JUNE 11, 2019

Mark McKeel  
**CITY HALL CAMPUS**  
101 East 11th Street; Suite G13  
Chattanooga, TN 37403

**RE: MAINTENANCE PROPOSAL**

Dear Mark McKeel:

Thank you for the time and interest you have given me concerning the subject of housekeeping for your facility. **JANI-KING OF CHATTANOOGA** appreciates this opportunity.

Enclosed is our completed proposal for a professionally operated cleaning program, including the cleaning schedule.

The total monthly charge represents your only cost, and is inclusive of:

- All labor
- All supervision
- All equipment for cleaning
- All payroll, payroll taxes, insurance, etc.

Each **JANI-KING** representative is fully covered by an insurance program that protects you and your business in several ways. This comprehensive program provides complete coverage, including General Liability, Workers' Compensation, Destruction, Dishonesty, and Disappearance Crime Insurance and Lost Key Insurance.

Please contact me at (423) 648-3101 in the event you have questions regarding this proposal or for additional information you deem necessary in assessing our proposal.

Trusting we may be of service,

Josh Sherwood  
Regional Director  
**JANI-KING OF CHATTANOOGA**

## THE JANI-KING FRANCHISING CONCEPT

JANI-KING is a commercial cleaning service, in the business since 1969 that has dramatically changed the commercial cleaning and maintenance industry.

JANI-KING recognized years ago that serious problems existed with conventional cleaning services. These problems stemmed from a lack of proper supervision and communication and little concern about a job well done. At JANI-KING, we realize that quality work is directly related to the individual workers' training, motivation and supervision. Locating quality individuals who possess the ability to consistently supervise and motivate cleaning personnel can solve these problems.

At JANI-KING, we looked for an individual who will care as much about your building as you do. Because we cannot provide individuals with ownership in your company or your building, acts which would surely promote the quality and concern that we look for; we offer individuals ownership in a business - a JANI-KING franchise.

The JANI-KING FRANCHISING CONCEPT has enabled us to provide clients throughout the world, both large and small, with a business person who has the intelligence, attitude, desire and determination to maintain the high cleaning standards that you demand for your building.

Each JANI-KING AUTHORIZED FRANCHISEE has successfully completed an extensive training program and, as a member of our team, have the procedures, personnel, equipment, insurance, bonding and support necessary to become an integral part of your maintenance program. Our franchisees' concern - the dedication to your building - cannot be equaled.

It is a pleasure to share the JANI-KING program with you, a program that has been the answer to cleaning problems encountered by building managers throughout the world.

Please do not hesitate to call us for any additional information you might need.

## **General Procedures**

### **I. Supervision**

- JANI-KING will stay in close contact with the management concerning all work performed.
- All JANI-KING personnel will be trained and supervised to perform to the best of their ability in order to accomplish the cleaning you deserve.
- All personnel will be checked regularly as to performances and ability to maintain JANI-KING standards.

### **II. Wage Scale**

- All personnel will be paid no less than the minimum wage required by Federal Law.
- Work hours, workweek, job methods, procedures, pay periods, and pay scale will be thoroughly explained to all personnel.

### **III. Security Procedures and Insurance**

- JANI-KING representatives will work closely with management in regard to the use of acceptable personnel.
- Before leaving the building, JANI-KING personnel will check to ensure that the building is properly secured.
- JANI-KING will provide all necessary insurance and bonds on all JANI-KING personnel.

**JANI-KING®**  
**MAINTENANCE AGREEMENT**

This Maintenance Agreement ("Agreement") is made as of the Effective Date below by and between Autumn Wind Franchising, Inc. d/b/a Jani-King of Chattanooga ("Jani-King") and CITY HALL CAMPUS ("Client").

WHEREAS:

- Jani-King is in the business of providing commercial cleaning and maintenance services; and,
- Client is desirous of the services of Jani-King for the purpose of keeping its premises properly cleaned as outlined in the Cleaning Schedule; and,
- Jani-King agrees to provide such services to Client.

THEREFORE, in consideration of the mutual covenants and obligations set out in the Agreement, the parties hereby agree as follows:

**1. PERFORMANCE OF SERVICES**

- 1.1. Performance of the services scheduled shall begin the \_\_\_\_ day of \_\_\_\_\_, 2019.
- 1.2. The term of this Agreement shall be for one (1) year from the date services are scheduled to begin.
- 1.3. The services shall be performed at the following location:

**BUILDING NAME:** CITY HALL CAMPUS  
**ADDRESS:** 101 East 11th Street; Suite G13  
Chattanooga, TN 37403

- 1.4. The premises making up the working area under this Agreement will be known further in the Agreement as the "Named Areas", which are further defined in the Cleaning Schedule, attached hereto and by specific reference made a part of this Agreement.
- 1.5. Jani-King agrees to service Named Areas as scheduled five (5) times per week.
- 1.6. Jani-King agrees to furnish all equipment and tools necessary for the performance of its duties. The duties being to maintain the Named Areas in a neat, clean and orderly condition as outlined in the Cleaning Schedule attached hereto and by specific reference made a part of this Agreement. Client warrants that the premises to be serviced are free of asbestos, hazardous materials and hazardous waste materials. Client hereby agrees to hold Jani-King and its authorized franchise owners harmless from any and all liability resulting from any Jani-King personnel or authorized franchise owner or its personnel's exposure to such hazardous or harmful materials.

**2. PAYMENT OF SERVICES**

- 2.1. Client agrees to pay to Jani-King each month the total minimum sum stated in the Pricing Schedule, contained herein, on or before the last day of each month in which services are rendered. Late fees will be assessed if payment is not received by the fifth day of the following month. Fees will equal 3% of the minimum sum stated on Pricing Schedule. Minimum charge of Fifty Dollars will apply. Additionally, Client also agrees to pay any sales or use tax levied by a taxing authority on the value of the services provided or supplies purchased. Client agrees that all payments due and owing Jani-King, for any reason, shall be properly credited only when delivered to the following address:

**Jani-King of Chattanooga**  
**609 Reliability Circle**  
**Knoxville, TN 37932**

- 2.2. Credits for holidays were pre-determined and given as part of the monthly charge herein, and no other adjustments will be made for those holidays.
- 2.3. From time to time, as the parties may agree, the amount to be paid by Client may be increased or decreased to reflect an increase or decrease in the area of space serviced and the kind, amount or frequency of service to be rendered. Such modifications shall be binding only if in writing, signed by both parties. In the event mutual agreement relating to frequency of service, type of service, space serviced or amount to be paid cannot be reached, the frequency of service, type of service, space serviced or amount to be paid shall remain unchanged.
- 2.4. It is expressly agreed that the total minimum sum stated in the Pricing Schedule may be increased annually by Jani-King by a percentage amount not to exceed the annual increase of the Consumer Price Index as most recently published in the Wall Street Journal.
- 2.5. In the event payment for services is not received within thirty (30) days from the date such payment is due, Jani-King may suspend services to Client until such payment is received. Suspension of services by Jani-King under this Section shall not deprive Jani-King of any of its remedies or actions against Client for past or future payments due under this Agreement, nor shall the bringing of any action for payment of services or other rights contained herein be construed as a waiver of any Jani-King rights.

### **3. INDEPENDENT BUSINESS RELATIONSHIP**

- 3.1. It is expressly agreed that Jani-King will select and designate all personnel to perform its obligations under this Agreement.
- 3.2. Jani-King and any of its personnel are not employees of Client but are independent contractors; and in this regard, such Jani-King authorized franchise owners and their employees will not be within the protection or coverage of Client's Workers' Compensation Insurance and no withholding of Social Security, Federal or State Income Tax or other deductions shall be made from the sums agreed to be paid to Jani-King herein, the same being contract payments and not wages.
- 3.3. Client agrees that during the term of this Agreement, and within one hundred and eighty (180) days after termination, that Client will not employ any employees, agents, representatives or franchisees of Jani-King without the express written consent of Jani-King. Jani-King agrees that during the term of this Agreement and within one hundred and eighty (180) days after termination, it will not employ any employees, agents or representatives of Client without the express written consent of Client.

### **4. RENEWAL AND TERMINATION**

- 4.1. This Agreement shall be automatically extended and renewed on each anniversary date on the same terms and conditions, unless either party shall give written notice, as described herein, of termination at least thirty (30) days prior to such anniversary date. If timely notice is given for termination, this Agreement shall expire at midnight of the anniversary date. Otherwise, this Agreement may only be terminated for non-performance as set out below.
- 4.2. Non-performance is defined as the failure, neglect or refusal to perform any act stipulated under this Agreement or as outlined in the Cleaning Schedule attached. Before any termination for non-performance is effective, the terminating party must give the other party written notice, as described herein, specifying in detail the nature of any defect or failure in performance. Upon the effective date of the receipt of notice of non-performance, Jani-King, at its election, shall have thirty (30) days in which to cure the defect in performance to the reasonable satisfaction of Client. In the event the defect is not satisfactorily cured at the end of the thirtieth (30th) day from the effective date of such notice, the terminating party shall provide written notification, as described herein, to the non-terminating party of the failure to satisfactorily cure the defect. This Agreement shall then terminate thirty (30) days from the date the second notice is received. In the event the second notice is not received within the specified time, all deficiencies will be deemed cured.

- 4.3. In the event Client terminates this Agreement for any reason other than non-performance as described above, Client agrees to pay, as liquidated damages, an amount equal to the total minimum sum stated in the Pricing Schedule multiplied by the number of months remaining under this Agreement.
- 4.4. All notices between Client and Jani-King shall be in writing. Any notice shall be deemed duly served if such notice is deposited, postpaid and certified, with the United States Postal Service, or a recognized common parcel courier providing express, receipted delivery to the address as stated in Section 2.1. Herein for Jani-King or to the address stated on the signature page of this Agreement for Client. All other notices, including notices personally delivered to individuals performing services under this Agreement, shall be ineffective. Either party may change the address of notice by providing the other party written notice of such change.

Time is of the essence for all notices required under the terms of this Agreement.

## 5. GENERAL PROVISIONS

- 5.1. In the event it becomes necessary for either party to institute suit against the other to secure or protect its rights under this Agreement, the prevailing party shall be entitled to all associated costs of the suit, including reasonable attorney's fees, administrative fees, court costs and damages as part of any judgment entered in its favor.
- 5.2. The terms of this Agreement shall be binding upon and inure to the benefit of Jani-King and Client and their respective heirs, representatives, successors and assigns, except as otherwise herein provided.
- 5.3. Any waiver by either party to this Agreement of a breach of any term or condition of this Agreement shall not constitute a waiver of any subsequent breach of the same or any other term or condition of this Agreement.
- 5.4. Jurisdiction and venue for any suit brought on this Agreement shall be in the governmental division of the county where the Jani-King regional office is located.
- 5.5. Both parties agree that they have fully reviewed and discussed the terms of this Agreement, and all attachments, and acknowledge that the terms reflect the entire Agreement of the parties pertaining to its subject matter and it supersedes all prior contemporaneous agreements, representations and understandings of the parties.
- 5.6. Any changes or modification to this Agreement must be in writing, signed by both parties and attached hereto.
- 5.7. In the event any section, subsection, provision or clause of this Agreement or any combination thereof is found to be unenforceable at law, in equity or under any presently existing or hereafter enacted legislation, regulation, or order of the United States, any state or subdivision thereof or any municipality, those findings shall not, in any way, affect any other part of this Agreement which shall continue in full force and effect, and the unenforceable provision shall be interpreted in a manner that imposes the maximum restriction or obligation permitted by law.

IN WITNESS WHEREOF, the Parties hereto have set their hands this \_\_\_\_ day of \_\_\_\_\_, 2019.

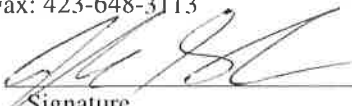
<p><b>Jani-King of Chattanooga</b> 7610 Hamilton Park Drive; Suites 3 &amp; 4 Chattanooga, TN 37421 Phone: 423-648-3101 Fax: 423-648-3113</p> <p> _____ Signature</p> <p>Josh Sherwood _____ Print Name</p> <p>Regional Director _____ Title</p>	<p><b>CITY HALL CAMPUS</b> 101 East 11th Street; Suite G13 Chattanooga, TN 37403 Phone: 423-643-7230 Fax:</p> <p>_____ Signature</p> <p>_____ Print Name</p> <p>_____ Title</p> <p>_____ E-Mail Address</p> <p>_____ Client's Contact Name (If different from signer)</p> <p>_____ Contact's E-Mail Address</p>
---	---

Billing information:

Julie Graci  
\_\_\_\_\_  
Account Payable Contact

609 Reliability Circle  
\_\_\_\_\_  
Billing Address

Knoxville TN 37932  
\_\_\_\_\_  
City, State ZIP

(865) 671-5464  
\_\_\_\_\_  
Account Payable Phone Number / Extension

(865) 671-0987  
\_\_\_\_\_  
Account Payable FAX Number

jgraci@jkccs.com  
\_\_\_\_\_  
Account Payable E-Mail Address

\_\_\_\_\_  
Purchase Order Number (if applicable)



## CLEANING SCHEDULE

### Named Areas:

A.	Bessie Smith, City Council Building, City Hall, City Hall Annex, Development Resource Center, Facilities Management Building, Lindsay Street Building, WellAdvantage Health and Fitness Center Hallways, Common Areas, Offices, Lobbies, Break Rooms
B.	Restrooms
C.	Floor Care Program
D.	Carpet Care Program

***\*\*Please See customer provided cleaning schedule in RFP.\*\****

## **PRICING SCHEDULE**

### **CITY HALL CAMPUS**

101 East 11th Street; Suite G13  
Chattanooga, TN 37403

The Named Areas will be serviced according to the Cleaning Schedule  
for a minimum monthly charge of:  
(Tax Not Included)

### **MAINTENANCE**

#### **Bessie Smith Cultural Center**

**Twenty Nine Thousand Eight Hundred Sixty Nine and No/100 Dollars**

**(\$29,919.00)**

**PER YEAR**

**Five (5) Times Weekly**

#### **City Council Building**

**Fifteen Thousand Seven Hundred Thirty Seven and No/100 Dollars**

**(\$15,787.00)**

**PER YEAR**

**Five (5) Times Weekly**

#### **City Hall Building**

**Seventy Four Thousand Two Hundred Six and No/100 Dollars**

**(\$74,256.00)**

**PER YEAR**

**Five (5) Times Weekly**

**City Hall Annex**

**Forty Three Thousand Nine Hundred Twelve and No/100 Dollars**

**(\$43,962.00)**

**PER YEAR**

**Five (5) Times Weekly**

**Development Resource Center**

**One Hundred Six Thousand One Hundred One and No/100 Dollars**

**(\$106,151.00)**

**PER YEAR**

**Five (5) Times Weekly**

**Facilities Management Building**

**Nine Thousand Four Hundred Eight and No/100 Dollars**

**(\$9,458.00)**

**PER YEAR**

**Five (5) Times Weekly**

**Lindsay Street Building**

**Nine Thousand Six Hundred Sixteen and No/100 Dollars**

**(\$9,666.00)**

**PER YEAR**

**Five (5) Times Weekly**

**WellAdvantage Health and Wellness Center**

**Twenty Six Thousand Three Hundred Seventy Seven and No/100 Dollars**

**(\$26,427.00)**

**PER YEAR**

**Five (5) Times Weekly**

## REQUESTED ADDITIONAL CLEANS

### FLOORS

Upon request, the following services can be performed for an additional fee:

- Carpet Shampoo - minimum charge of \$150.00 or \$0.17 per square foot
- Strip, reseal and refinish tile floors - minimum charge of \$150.00 or \$0.245 per square foot.
  - Care will be taken to get into corners, along edges and beneath furniture.
  - Care will be exercised so that baseboards, walls and furniture shall not be splashed, marred, disfigured or damaged during these operations.

### WINDOWS

Upon request, the following services can be performed for an additional fee:

- Windows can be washed inside and out up to second floor with the use of a step ladder - minimum charge of \$50.00.

**\*Prices are subject to change\***

## Jani-King of Chattanooga Addendum Response

### Jani-King anticipates the following staff levels at each building to complete work:

Bessie Smith: Two (2) staff members

City Council Building: Two (2) staff members

City Hall: Three (3) staff members

City Hall Annex: Two (2) staff members

Development Resource Center: Three to Four (3-4) staff members

Facilities Management: One (1) staff member

Lindsay Street Building: One (1) staff member

WellAdvantage Health and Wellness Center: Two (2) staff members

### Equipment used to clean each floor type in each building:

Carpet: Proteam or similar commercial backpack vacuum cleaner will be used for daily cleaning. Extractions will be done using a commercial grade carpet extractor.

Hard Surface floors: For daily cleaning, Jani-King will use a flat mop system using microfiber mopping heads.

Hard surface floor maintenance: Buffing will be done using a high speed burnisher with corresponding buffing pads. Stripping and refinishing will be done using a low speed floor machine and wax will be applied using a flat mop system to ensure even coats with proper coverage.

Mondo Flooring: Daily cleaning will be done using a dust mop and backpack vacuum. Mopping will be done using a conventional mop head with cleaning solutions that do not contain dyes to ensure floor does not stain. Spot scrubbing will be done using a deck brush and deep cleaning will be done using a low speed floor machine with corresponding pads to remove stains and scuffs.



---

## **REFERENCES**

# **JANI-KING OF CHATTANOOGA**

---

Partial Listings

### **T-MOBILE CALL CENTER**

6730 Customer Delight Drive  
Chattanooga, TN 37421  
(423) 598-4016  
Willie Watson

### **CHATTANOOGA RIVERWALK**

1503 Middle Street  
Chattanooga, TN 37408  
(423) 643-6126  
Morgan McCormick

### **ABRA AUTO BODY & GLASS**

6009 International Drive  
Chattanooga, TN 37421  
(423) 510-0600  
Valarie Nash

**Additional References Available upon Request**